

# **Cross Border Proxy Voting**

## **Case Studies from the 2002 Proxy Voting Season**

A report commissioned by the International Corporate Governance Network

## **Contents**

<b>Acknowledgments</b>	3
<b>Executive summary</b>	4
<b>Introduction</b>	8
<b>1 The rise in cross border proxy voting</b>	10
<b>2 Frequently cited obstacles to cross border proxy voting</b>	15
<b>3 The practice of cross border proxy voting revealed in the ICGN study</b>	23
<b>References</b>	34
<b>Appendices</b>	
A Methodology	36
B Project participants	38
C The greatest obstacles to cross border voting	39
D Case studies	42
E Sample questionnaire (for investment managers)	72

## **Acknowledgments**

My thanks go first and foremost to the ICGN Committee on Cross Border Voting Practices. I am particularly grateful to John Wilcox, the Chair of the Committee, who helped steer the study through from inception to completion.

Sponsorship of the study was provided by the membership of the ICGN and additional contributions were generously provided by the following organizations: BP plc, Hermes Investment Management Ltd, Investment Company Institute, Lloyds TSB Registrars and TIAA-CREF Institute.

Throughout the course of the study, I have relied upon the advice and assistance of my colleagues Jonathan Bates, Owen Cameron and Merlin Underwood. Special thanks also to Stephen Midwinter for his analysis of the national rules and regulations governing proxy voting.

Finally, I owe a particular debt of gratitude to all the people who took time out of their busy schedules to subject themselves to my inquiries.

David Ladipo  
January 2003

## Executive Summary

---

**An international study conducted by Institutional Design shows how cross border proxy voting works in practice today. The study audits the transmission of proxy materials and voting instructions between five issuers (one each from the US, UK, Germany, Japan and Italy) and six investment managers (three from the UK and three from the US). Commissioned by the International Corporate Governance Network, the first phase of the audit was conducted during the 2002 proxy voting season, the key findings from which are presented below.**

---

### Key findings

- In the case studies involving the US and German issuers, all the investment managers were satisfied with the length of time between the receipt of proxy materials and the voting deadline. Only a few participants experienced the late receipt of proxy materials issued by the UK and Italian issuers. However, in the case studies involving the Japanese issuer, there were several complaints about the timing of its AGM and the late receipt of its proxy materials.
- Investment managers were well supplied with the annual reports published by the US, UK and German issuers but only one manager received the annual report from the Italian issuer and none received the annual report released by the Japanese issuer.
- Investment managers still found it hard to obtain the full text of meeting notices. In many cases, the distribution mediums that connect sub-custodians to global custodians did not cater for the transmission of complete (unabridged) resolutions and agendas.
- Although German banks usually allow deposited shares to be traded up to 24 hours before company meetings, investment managers and custodians still perceived of share-blocking as a 'major obstacle' to proxy voting in Germany.
- Despite the growing use of electronic instruction mediums, investment managers still found it difficult to verify whether their global custodians/voting agents had received and acted upon their vote instructions. Although confirmation of receipt was provided in most of the cases involving the US and UK issuers, such receipts were less common in the cases involving the German, Italian and Japanese issuers.

- Even when investment managers could verify the receipt of vote instructions by their global custodians/voting agents, they were rarely able to audit the onward transmission of these instructions to sub-custodians and company registrars.
- Bearing (or ascribing) individual responsibility for the successful receipt or dissemination of proxy voting materials is frustrated by: the length and complexity of the proxy voting chains; the multiplicity of persons involved in the process; and the wide variation in the content and format of the materials.
- The proxy chains linking investment managers to global custodians are being streamlined as a result of the consolidation of the global custody industry and the development of global proxy voting agents. The continuation of these processes - along with the introduction of new technologies and the use of proxy solicitors - will help to reduce some of the obstacles to cross-border proxy voting.
- However, notwithstanding the impact of market forces and new technologies, many of the problems encountered by the case study participants (e.g. voting on a show of hands in the UK, share-blocking in Italy, the concentration of meetings in Japan, or the hard copy delivery of proxy materials to registrars) may have to be resolved through: the reform of national laws, the development of: standards at the EU level, the evolution of stock exchange requirements and the adoption of voluntary standards by corporations.
- International bodies, such as the ICGN, will continue to monitor these problems and urge their swift resolution; but the requisite reforms will require the concerted efforts of policy makers and market participants.

### About the case studies

The case studies consist of 25 pairs of issuer-to-investor 'proxy chains'. The data contained in these studies is based on questionnaires administered to five global issuers, six cross-border investors, four global custodians, two proxy voting agents and one proxy solicitor. Each study tracks a) the flow of proxy materials from the issuer down through each custodial layer until their receipt by the voting decision maker and b) the return of voting instructions up through each custodial layer until their receipt by the issuer. Along each point in this process, the case studies audit transaction and message formatting as well as timing and completeness of transmittals. All the studies were conducted between June and October 2002.

## Sponsorship

The research was commissioned by the International Corporate Governance Network (ICGN) and conducted by Institutional Design with the assistance of Georgeson Shareholder Communications. Sponsorship was provided by the ICGN and by the following organisations: BP plc, Hermes Investment Management Ltd, Investment Company Institute, Lloyds TSB Registrars and TIAA-CREF.

## Membership of the ICGN Committee on Cross Border Voting Practices

### **Mr. John C. Wilcox – Committee Chairman**

Vice Chairman  
Georgeson Shareholder  
Communications Inc.

### **Mr. Philip Armstrong**

Managing Director  
ENF Corporate Governance Advisory  
Services (Pty) Ltd.

### **Ms. Jennifer S. Choi**

Assistant Counsel  
Investment Company Institute

### **Mr. Tim Clarke**

IT Director  
The Manifest Voting Agency Ltd.

### **Dr. Andrew Mark Clearfield**

Director  
International Corporate Governance  
TIAA-CREF

### **Mr. David F. Dando**

Director of European Operations  
Investor Responsibility Research Centre  
(IRRC) Ltd.

### **Dr. Stephen M. Davis**

President  
Davis Global Advisors Inc.

### **Mr. Stanley J. Dubiel**

Vice President & Director, Global  
Research  
Institutional Shareholder Services (ISS) Inc.

### **Ms. Michelle Edkins**

Director  
Hermes Investment Management Ltd.

### **Mr. Harry L. Frost, II**

Consultant to ADP Investor  
Communication Services – Europe  
(ADP ICS)

**Mr. Paul Lee**

Shareholder Engagement Manager  
Hermes Investment Management Ltd.

**Mr. Pierre-Henri Leroy**

President  
Proxinvest

**Mr. Alan MacDougall**

Managing Director  
Pensions Investment Research  
Consultants (PIRC) Ltd.

**Prof. Christine A. Mallin**

Professor of Finance and Director of  
Centre for Corporate Governance  
Research, The Birmingham Business  
School

**Mr. Ian Matheson**

Independent member

**Mr. Robert McCormick**

Director, Investment Proxy Research  
Fidelity Management & Research  
Company (FMR & Co)

**Mr. Theodore A. Rothschild**

Vice President  
Senior Product Manager  
JPMorgan Investor Services

**Mr. Kurt N. Schacht, CFA**

Wyser-Pratte Asset Management

**Ms. Linda S. Selbach**

Principal, Global Proxy Group  
Barclays Global Investors N.A.

**Mr. Peter Swabey**

Manager of Investor Relations  
Business Development  
Lloyds TSB Registrars

**Mr. Dario Trevisan**

Trevisan & Associati

**Mr. Jaap W. Winter**

Partner  
De Brauw Blackstone Westbrook

How to obtain further information

Further information about the Cross Border Proxy Voting Study can be obtained from Jonathan Bates, Principal, Institutional Design, 36 St John's Lane, London, EC1M 4BJ, Tel: + 44 207 336 6606, Email: [jib@institutionaldesign.com](mailto:jib@institutionaldesign.com)

## Introduction

A key factor in the accountability of companies to owners is the process by which shareholders vote. With ownership spreading widely across frontiers, attention has focused on the efficiency of systems addressing cross border voting. However, barriers in the form of cost, logistics, regulation and law make it difficult for many institutions based outside the home market to exercise their full responsibility as owners and vote. As a consequence, company boards - particularly those heading firms with internationally diverse shareholders - risk being more remote from their owners' interests. Institutions, for their part, are hampered when they seek to use a legitimate tool to convey support or warnings to management.

The ICGN recognizes that variations in voting rights themselves, in addition to procedural problems, can present barriers to the exertion of shareholder influence. Voting rights clearly vary across markets but the principle adopted by the ICGN is that every market and every issuer in that market should strive to ensure that equitable voting procedures exist for their shareholders.

In support of this principle, the ICGN Committee on Cross Border Voting Practices resolved to conduct a study of the conduct of the 2002 proxy voting season. The aims of the study were to explore and explain exactly how cross border voting works in practice today, to uncover bottlenecks, to understand voting policies and practices, to explore how specific national rules and regulations influence share voting, and to determine the extent to which end-to-end vote confirmation is (and can be) achieved.

The Committee divided the study into three phases. Phase 1 would map and describe the activities of targeted issuers, institutional investors, global custodians, voting agents and other market intermediaries involved in the exercise of cross border voting<sup>1</sup>. This phase (of which this report is the outcome) would serve as the prelude to a more detailed analysis of the causes of, and solutions to, the obstacles to cross border proxy voting. The third and final phase of the project would involve the drafting of specific recommendations for each market along with a set of global principles applicable to all issuers and investors.

### The case studies

The first phase of the project was approved by the ICGN Board of Governors on April 2, 2002 and on April 17, 2002 the ICGN engaged an independent consultancy (Institutional Design Limited) to assist in the conduct of the study. During the months of April and May, the Committee actively solicited the participation in the study of a range of global issuers and institutional investors. By the end of May, it had secured the commitments of five global issuers (one each from the UK, the US, Italy, Germany and

---

<sup>1</sup> The Committee agreed that the first phase of the project would not be intended as a critique of the governance standards, the local legal requirements, or the behaviour of issuers or investors affecting cross border voting. Its purpose would simply be to describe the system as it currently works in practice.

Japan) and six global investors (three from the UK and three from the US) forming 25 pairs of issuer-to-investor 'proxy chains' (as described in Appendix D).

Along each of these pairs, Institutional Design tracked a) the flow of proxy materials from the issuer down through each custodial layer until their receipt by the voting decision maker and b) the return of voting instructions up through each custodial layer until their receipt by the issuer. Transaction and message formatting, as well as timing and completeness of transmittals, were audited at each point in the process. All the studies were conducted between June and October 2002.

### **The contents of the report**

Part 1 examines the factors that have increased the demand for cross border proxy voting. These include the growth in cross border equity investment, the introduction of electronic forms of communication between companies and shareholders and the rise in (transnational) shareholder activism. The chapter also examines the emergence of new regulations obligating institutional investors to vote their holdings.

Part 2 describes some of the more frequently cited obstacles to cross border proxy. These include the problems caused by short notice periods, delays in the receipt of proxy materials and the return of proxy voting instructions. Other obstacles include: share-blocking, 'obstructive' local protocols<sup>2</sup>, the inadequacy or insufficiency of proxy voting materials, the inability to confirm vote execution and the legal uncertainty over who, in cross border situations, is entitled to control the voting right.

Part 3 provides an overview of the information contained in the case studies and reveals the extent to which the oft-cited obstacles to cross border proxy voting were encountered by the participants.

Appendix A describes the case study methodology. Appendix B lists the project participants. Appendix C lists the 'greatest obstacles to cross border proxy voting' – as perceived by the case study participants. The case studies themselves are contained in Appendix D and Appendix E contains an example of one of the questionnaires used to elicit the case study data.

---

<sup>2</sup> e.g. restrictions on the number of shareholders that can be represented by a proxy.

## 1 The rise in cross border proxy voting

The growth of cross border proxy voting<sup>3</sup> reflects the rapid increase in cross border equity investment. In the UK, for example, the percentage of shares in foreign ownership grew from 3.6% in 1981 to 31.9% in 2001 (Figure 1) and the (real) value of UK overseas portfolio investment grew from £67bn in 1987 to £387bn in 2001 (Figure 2). Meanwhile, on the other side of the Atlantic, the share of foreign equities in US investors' portfolios rose from just over 1 per cent in 1980 to 12 per cent in 2001, where it stood at a total of \$1.6 trillion (approximately 15% of US GDP)<sup>4</sup>. Although Britain was the favoured location for US overseas portfolio investment, by the end of the 1990s, US investors held a small but sizeable share of the stock markets in Italy, Germany and Japan (Figures 3 & 4). Most commentators expect these trends to continue over the next ten years, particularly in Europe where the introduction of the Euro should stimulate cross border investment by eliminating the foreign exchange risk on investment in other EMU member countries<sup>5</sup>.

However, the increase in cross border voting also reflects a more general increase in proxy voting, a phenomenon encouraged by policy makers and shareholder activists, and facilitated by the emergence of new technologies. At the same time as investors were busying expanding their overseas portfolios, legislators and regulators were urging a more responsible attitude towards proxy voting. The US led the way in 1988 when the Department of Labor (DOL) issued a set of guidelines directing Employee Retirement Income Security Act (ERISA) fund managers<sup>6</sup> to vote proxies with the same diligence shown when making other fiduciary decisions<sup>7</sup>. In 1994, the DOL strengthened this directive by requiring fund managers to disclose their voting records to ERISA

---

<sup>3</sup> When we use the term 'proxy voting' we mean the process by which an investor submits voting instructions which may be counted in a shareholders meeting even though the investor is physically not present at the meeting.

<sup>4</sup> Warnock (2001, p.1) and IMF (2001).

<sup>5</sup> Winter 2000.

<sup>6</sup> Though ERISA only applies to private pension funds, the same provisions have been adopted by several states with regard to their public pension schemes and the Comptroller of the Currency - a regulator of the banking system - has undertaken to apply a similar test to banks voting as trustees (Baums and Wymeersch 1999, p.365).

<sup>7</sup> The Department of Labor has also made it clear that: "the same principles apply for proxies appurtenant to shares of foreign corporations, the Department recognizes that in voting such proxies, plans may, in some cases, incur additional costs. Thus, a fiduciary should consider whether the plan's vote, either by itself or together with the votes of other shareholders, is expected to have an effect on the value of the plan's investment that will outweigh the cost of voting. Moreover, a fiduciary, in deciding whether to purchase shares of a foreign corporation, should consider whether the difficulty and expense in voting the shares is reflected in their market price" (Bulletin 94-2).

fiduciaries<sup>8</sup> and in 2002, the SEC proposed to implement a new rule extending this disclosure requirement from the managers of ERISA to the managers of mutual funds<sup>9</sup>.

The principles articulated by the US government (in respect of proxy voting) have also been mirrored by policy makers in the UK. They can be seen in the Combined Code of Corporate Governance which clearly states that: "Institutional shareholders have a responsibility to make considered use of their votes...and should take steps to ensure that their voting intentions are being translated into practice." They can also be seen in the recent Amendment to the 1995 Pensions Act requiring pension fund trustees to prepare a Statement of Investment Principles specifying the trustees' policy on voting their shares. In addition, the UK government (in its response to the Myners review of institutional investment) has signaled its intention to enact legislation making it a requirement for *both* trustees *and* fund managers to vote proxies on issues that may affect the value of their beneficiaries' investments<sup>10</sup>. More recently, the Institutional Shareholders' Committee has issued a statement of principles urging institutional shareholders and/or agents to 'vote all shares held directly or on behalf of clients wherever practicable to do so' and 'maintain a clear audit trail...of votes cast'<sup>11</sup>.

In Italy, a similar requirement was introduced in the Unified Text of Rules on Financial Services that came into effect on 1st July 1998. Article 40 of the Text places a *general* duty of care on investment managers in dealing with their clients' money and Article 40(2) creates a *specific* duty to vote by providing that 'in the interest of beneficial holders', fund managers will 'attend to' the exercise of the right to vote in respect of financial instruments involving the managed funds'<sup>12</sup>.

In Japan and Germany, there is (as yet) no direct regulatory pressure on institutional investors to vote their holdings. Nonetheless, an amendment to the Japanese Law on

---

<sup>8</sup> Prior to 1994, money managers had to disclose their votes to ERISA fiduciaries only in *general* or *aggregate* form i.e. they didn't have to disclose how they voted in particular situations. But in 1994, the US Department of Labor issued Interpretative Bulletin (94-2) which stated that: "the proxy voting records must enable the named fiduciary to review not only the investment manager's voting procedure with respect to plan-owned stock, but also to review the actions taken in individual proxy voting situations".

<sup>9</sup> In addition, the SEC's proposal would go further than the ERISA requirement in that DOL does not require disclosure of voting records to the beneficiaries of an ERISA plan but disclosure only to the fiduciaries (e.g., trustees of the plan). The SEC proposal would not limit disclosure to the fiduciaries of a mutual fund (mutual fund directors) but would require public disclosure of the voting record.

<sup>10</sup> The Consultation Document released by the Department of Work and Pensions suggests that the duty to vote (imposed on ERISA fiduciaries and fund managers) should be treated in the UK not as an *absolute* duty to vote but as a duty to *consider* whether it is in the best interests of the beneficiary to do so, bearing in mind the view that relying on exit alone may provide inadequate protection for shareholders. Hence, the wording of the proposed rule is as follows: "Any person who is responsible for the investment of the assets of a retirement benefits scheme must, in respect of any company or undertaking (wheresoever resident or incorporated) in which they invest such assets, use such rights and powers as arise by virtue of such investment in the best interests of the members and beneficiaries of such scheme" (Encouraging Shareholder Activism: A Consultation Document available online at [www.dwp.gov.uk](http://www.dwp.gov.uk)).

<sup>11</sup> [www.abi.org.uk](http://www.abi.org.uk)

<sup>12</sup> Also noteworthy is Article 139 of the Text, which creates a right for minority shareholders to engage in proxy solicitation, potentially enabling more effective participation by institutional investors.

Investment Trusts and Companies (promulgated on 1 June 2000) has greatly expanded the investment powers of pooled funds and imposed a new set of duties on fund managers including: a duty to act loyally for investors, a duty to exercise the care of a good manager when conducting business, and liability for damages inflicted on investors. These duties are not dissimilar to those imposed upon institutional investors by the UK and Italian governments and are likely to encourage further moves in the direction of a positive duty to vote<sup>13</sup>. Likewise, by directing German companies to facilitate the exercise of proxy votes, the new Cromme Code on Corporate Governance<sup>14</sup> will have encouraged institutional investors to play a more active role in proxy voting<sup>15</sup>.

**Figure 1:** UK portfolio investment abroad (equity securities) £billion, valued at end of period

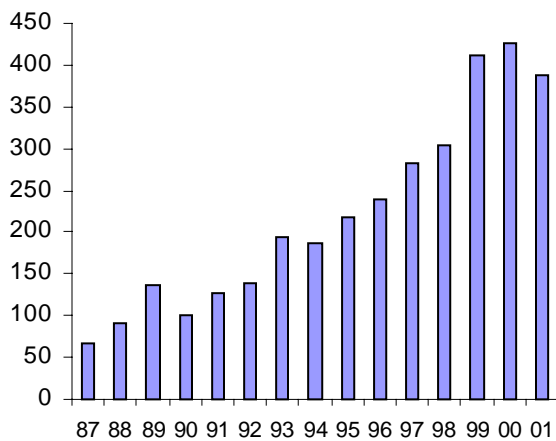

Source: (ONS 2002)

**Figure 2:** Foreign ownership of UK Shares 1981 - 200

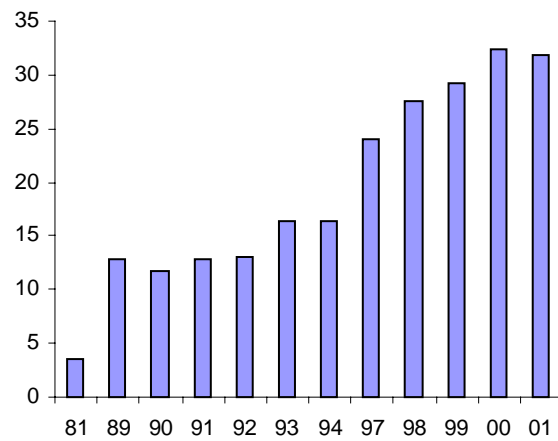

(Source: ONS 2002)

Non-governmental organizations - such as the Investment Responsibility Research Centre, PIRC, the OECD and the ICGN<sup>16</sup> - have also been encouraging investors to make greater use of their proxy votes. From the late 1980s to the mid 1990s, the

<sup>13</sup> The likelihood of such developments will have been increased by the reform of pensions law in Japan. The Corporate Pension Law 2001, which entered into force in April 2002, created several new types of pension for the Japanese market – including defined contribution and defined benefit pensions. The law includes provisions relating to the investment policies of such pensions, in particular permitting higher-risk investments than had been the case hitherto, which may encourage greater equity investment by Japanese pension funds.

<sup>14</sup> [www.corporate-governance-code.de](http://www.corporate-governance-code.de).

<sup>15</sup> Article 2.3.3 of the Code provides that: “The company shall facilitate the personal exercising of shareholders’ voting rights. The company shall also assist the shareholders in the use of proxies. The Management Board shall arrange for the appointment of a representative to exercise shareholders’ voting rights in accordance with instructions; this representative should also be reachable during the General Meeting.”

<sup>16</sup> At its fourth annual conference in San Francisco, the ICGN asserted that ‘access to the share vote is a key factor in the accountability of companies’. It further acknowledged that ‘the prudent obligation of fiduciaries is to consider the share vote an asset to be used to protect and further the shareholder’s interests on the grounds that voting can positively influence an investee company’s performance’ ([www.icgn.org/conf2k/share\\_voting.html](http://www.icgn.org/conf2k/share_voting.html)).

shareholder activism championed and supported by such organizations was principally directed at US companies. But over the past five years, shareholder activism has become an increasing transnational activity<sup>17</sup>.

**Figure 3:** Distribution of US holdings of foreign securities as of 31 December, 2001

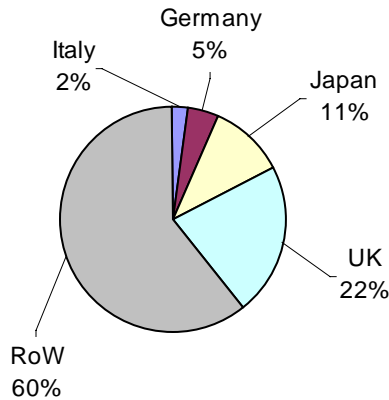

Source: Federal Reserve Board (2002)

**Figure 4:** US ownership as a percentage of equity markets in Italy, Germany, Japan & the UK in 2001

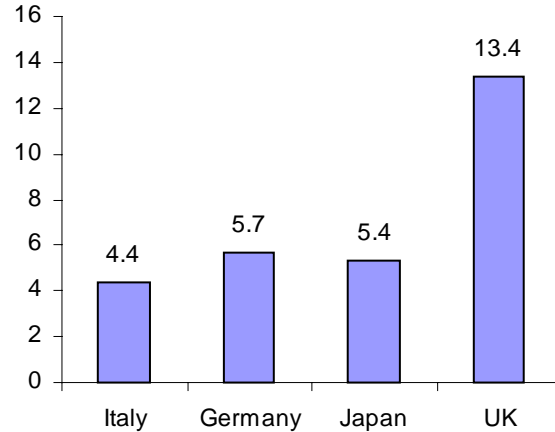

Source: Federal Reserve Board (2002) and IMF (2001)

Meanwhile, the introduction of electronic forms of communication (between companies and shareholders) has made it easier for shareholders to receive their proxy voting materials and return their vote instructions. This development is particularly noticeable in the US, where electronic proxies are allowed in more than 20 US states (up from just 14 in 1998) and thousands of publicly traded US companies are now open to internet proxy voting<sup>18</sup>. In the UK, the introduction of the Electronic Communications Order (on December 22, 2000) has encouraged the electronic transmission of meeting notices and other proxy materials and the use of electronic signatures in proxy appointments<sup>19</sup>. In Japan, the new Securities and Exchange Law permits issuers to deliver prospectuses and related information electronically<sup>20</sup>, and in Germany, the Stock Corporation Act has

<sup>17</sup> Research conducted by the IRRC shows that outside of the US, shareholder activism (measured in terms of the number of shareholder-sponsored resolutions) takes place primarily in Japan, Germany, France and the UK (Arnold 1999, p.393). The IRRC study shows that: “Despite the attention given to US activism heading overseas, local investors remain the predominant proponents of shareholder proposals around the globe”. However, recent years have seen a number of high-profile cross border shareholder proposals, including those submitted to BP (the oil company) at each of its last three AGMs: although BP is a British company, most of the signatories to the proposals were provided by American investors/activists.

<sup>18</sup> Significantly, those states that do allow it (Delaware, New York and California, for example) are home to a disproportionately large share of corporations (Georgeson Shareholder 2001).

<sup>19</sup> ECO (2000, Articles 12-21).

<sup>20</sup> [www.mof.go.jp](http://www.mof.go.jp)

been amended to allow for electronic signatures on the appointment of a company named proxy<sup>21</sup>.

The combination of these effects (the regulatory pressure to vote, the growth in shareholder activism and the emergence of new technologies) are well illustrated in the UK, where average voting levels across all shareholders have risen from 20% in 1990 to 56% in 2002 (Figure 5)<sup>22</sup>.

**Figure 5: Voting rates in the UK, 1990-2002**

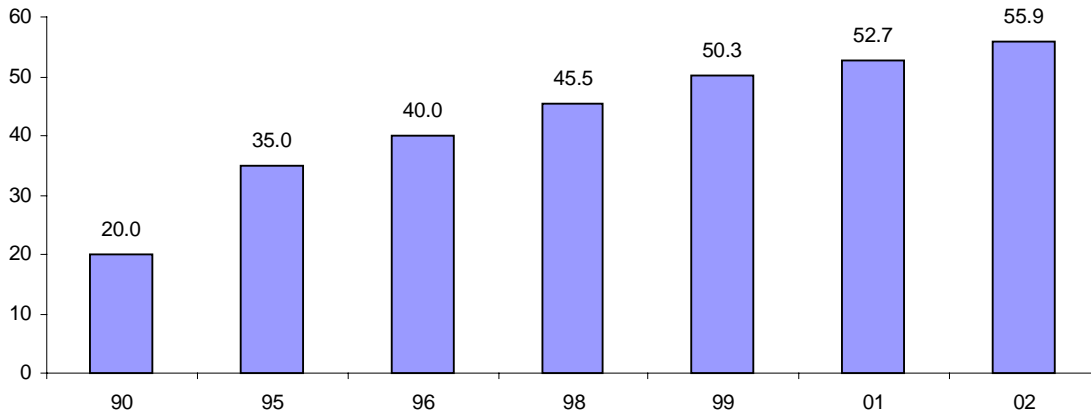

Source: NAPF (1999), PIRC (1999) and Manifest (2002)

<sup>21</sup> Noack (2002, p.6).

<sup>22</sup> See NAPF (1999, p.13), PIRC (1999, p.1) and Manifest (2002, p.3). Nevertheless, despite these trends, the UK's proxy voting levels still remain well below the 83% level witnessed in the United States (Manifest 2002, p.9).

## 2 Frequently cited obstacles to cross border voting

In 2001, the ICGN took a sample of its membership – comprised of a mix of global custodians, voting agents, investment managers and pension scheme trustees<sup>23</sup> – and asked them to list the ‘three key issues relating to cross border share voting’. As illustrated in Figure 6, the two most frequently cited issues were those of timeliness (i.e. the difficulties caused by short notice periods, delays in the receipt of proxy materials and the return of proxy voting instructions) and share-blocking. Other frequently cited problems included ‘local protocols’ e.g. wet signature requirements and restrictions on the number of shareholders that can be represented by a proxy. Several respondents also complained about the inadequacy of proxy voting materials i.e. the lack of sufficient information upon which to make a considered vote. Other issues cited included vote confirmation, language difficulties, inadequate voting rights and ‘lack of uniformity across borders’. Examples of each of these issues are contained in the sections below.

**Figure 6:** The key issues relating to cross border share voting as identified by the ICGN member institutions (the X axis indicates the number of times the issue was cited as one of the “three key issues”).

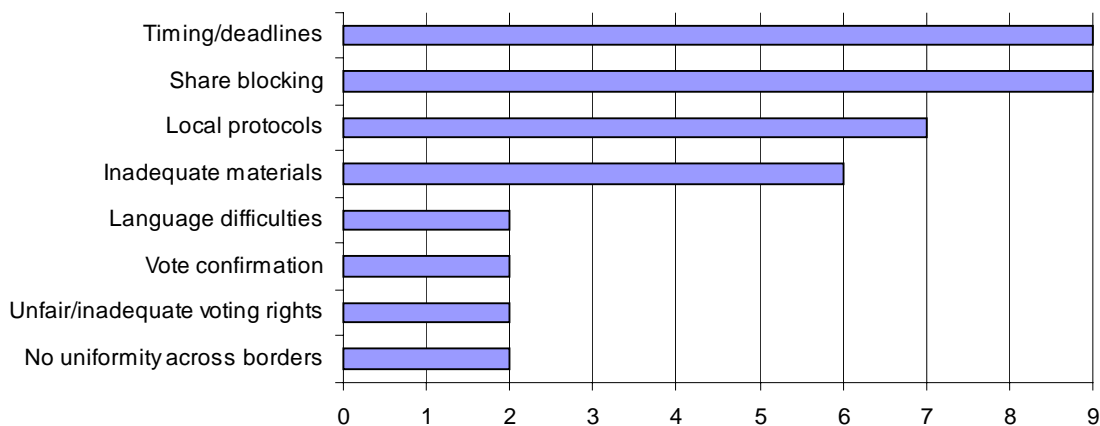

Source: Mallin (2001)

### Timeliness

For shareholders to make considered use of their vote, it is essential that they receive their proxy materials with sufficient time to make an informed decision. Unfortunately, this is not always the case, particularly in countries such as Japan where firms are required to release their convening notices only 14 days before the meeting (see Table 1) and, in practice, most companies wait until exactly 14 days before the meeting and use regular mail services. As described by the IRRRC: ‘this means that an investor with a large number of Japanese equities and the custody and sub-custody banks involved in

<sup>23</sup> The list of respondents comprised the following: Lens Investment Management, Barclays Global Investors, Standard Life Investments, Institutional Shareholder Services, Coal Pension, USS, Delta Airlines Benefit Trusts, HSBC Asset Management (Europe) Ltd, Ethos Foundation, Hermes Investment Management, JP Morgan Investor Services, Schroder Investment Management, The Manifest Voting Agency, OMERS, NYS Common Retirement Fund, Colonial First State, JP Morgan Fleming, SPF Beheer.

transmitting the ballot, must process the vote in what amounts to a 24-48 hour time period<sup>24</sup>. The problems created by this short notice period are compounded by the fact that in Japan, it is the custom for the annual shareholders' meetings of more than 80% of the publicly listed companies to be organized on the same day<sup>25</sup>. Moreover, these problems are particularly acute for cross border investors, as their portfolios tend to be held through a longer chain of intermediaries<sup>26</sup>.

---

<sup>24</sup> 'Japanese firms claim that one of the reasons for the short notification period is that firms are required to hold a general meeting within three months of fiscal closing, giving them little time to prepare' (Arnold p.395).

<sup>25</sup> The oft-cited justification for this practice is that it protects the management of Japanese companies from the unwanted presence of Japanese gangsters (*Sokaiya*) who would otherwise disrupt the shareholders' meetings (Winter 2000, p.6).

<sup>26</sup> As described by the IRRRC, 'what has come to be known as "Japan Week" is always a dreaded event during which working around the clock raises anxiety about missing a general meeting or a vote. And for beneficial owners, the worry that their vote may not be cast is high' (Arnold 1999, p.395).

**Table 1:** Comparison of proxy voting provisions

	UK	US	Germany	Italy	Japan
Minimum notice of AGM	21 days	28 days	28 days	30 days	14 days
Share depositing required	No	No	8 days before meeting	5 days before meeting	No
Share blocking required	No	No	No	Yes	No
Poll or show of hands	Show of hands most common	Poll	Poll	Poll vote most common	Poll
Quorum requirements	Very low (often no more than 5 members are required for a meeting to be quorate)	At least 50% of outstanding shares	(Typically) none <sup>a</sup>	At least 50% of outstanding shares at first convocation <sup>b</sup>	At least one third of outstanding shares <sup>c</sup>
Requirement to distribute proxy materials to beneficial owners	No	Yes	Yes (to some beneficial owners) <sup>d</sup>	No	No
Electronic proxy appointments permitted	Yes	Yes	Yes	No	No
Proxies can be granted to officers of the company	Yes	Yes	Yes	No	At company's discretion <sup>e</sup>
Release of poll results	Recommended in Combined Code	Mandatory for all votes	Mandatory for all votes	Mandatory for all votes <sup>f</sup>	At company's discretion

**Notes:**

<sup>a</sup> The German Stock Corporation Act does not require a quorum to conduct business at a shareholders' meeting. German companies are permitted to set quorum requirements in their corporate articles; however, in practice, these provisions are unusual (ICI 2000, p.168).

<sup>b</sup> According to Article 2368 of the Italian Civil Code, in an ordinary meeting at the first convocation, at least 50% of the shares eligible to vote have to be represented and at least a majority of those shares has to support action. At the second convocation no quorum is needed besides a vote by a majority of the shares present.

<sup>c</sup> A provision in the Interim Draft Revision of the Japanese Commercial Code lowers the quorum required at shareholders meeting for the approval of an extraordinary resolution from the currently required level of one-half to one-third of outstanding shares (Hashimoto 2002, p.6).

<sup>d</sup> The German Stock Corporation Act provides that the management board must furnish banks and shareholders' associations with information about shareholders' meeting. These notices are required to be communicated within 12 days of publication in the Federal Bulletin. The banks must transmit these notices to every shareholder for whom they hold shares on deposit and are reimbursed for this service by the company (Baums & Schmitz 1999, p.13).

<sup>e</sup> Under Japanese law, a shareholder can delegate authority to any other person to vote shares at shareholders' meetings. However many companies specify in their corporate articles that only another shareholder can act as a proxy (ICI 2000, p.60).

<sup>f</sup> Although there is no specific provision contemplating the right of shareholders to examine the results of a vote cast at a shareholders' meeting, under the Civil Code, shareholders have the right to examine the minutes of the meeting.

Although timing issues are particularly acute in Japan, complaints about timing can be heard in most other countries (with the possible exception of the United States). In Britain, for example, the 1999 Inquiry into UK Vote Execution<sup>27</sup> revealed that the most commonly cited problems with the UK's proxy voting system were those of tight deadlines and late receipt of proxy forms – the impact of which falls most heavily on cross border investors. The consequences of this are hinted at in a recent report by Manifest, a UK based voting agency, which shows that proxy voting rates are considerably lower amongst the FTSE 100 companies than they are amongst the rest of the FTSE All-Share index. Given that FTSE 100 companies also have a much higher proportion of foreign ownership, Manifest suggests that their voting rates may reflect the fact that operational difficulties (e.g. late delivery of proxy forms or late receipt of proxy vote instructions) are greater for cross border investors than for domestic investors<sup>28</sup>.

**Figure 7: Voting rates in the UK in 2002 by size**

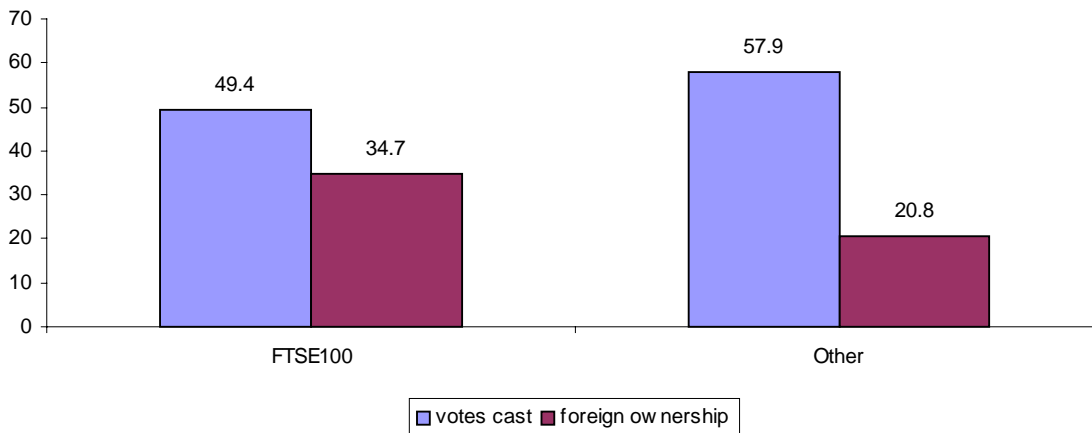

Source: Manifest (2002) and ONS (2002)

## Share blocking

A good example of this obstacle to cross border proxy voting can be found in Italy, where bearer shares can only be voted if they are deposited at a designated institution (such as a bank, custodian or broker) and blocked from trading for a period of several days in advance of the general meeting<sup>29</sup>. Not surprisingly, many investors (particularly

<sup>27</sup> (NAPF 1999).

<sup>28</sup> On the other hand, Manifest acknowledges that these rates might also reflect a lack of *interest* amongst foreign investors in the governance of UK plcs. Foreign ownership of UK shares is distributed as follows: EU (37%), Other Europe (2%), Offshore UK (1%), America (33%), Asia (21%), Africa (7%), Australasia & Oceania (0.3%). The weight of US investors amongst this group ought to have exerted an upward pull on voting rates, because US institutional investors are required to exercise votes as part of their fiduciary responsibility. But the weight of European and other non-US investors is likely to have pulled in the opposite direction, in so far as investors from these countries appear to display less interest in governance and voting matters than their Anglo-American counterparts.

<sup>29</sup> ICI (2000, p.178). The reason for the introduction of share blocking in bearer share markets relates to the difficulties of establishing the *bona fides* of persons wishing to attend the meeting. Absent a

those in the US and UK) find these requirements unduly restrictive and, as a consequence, are reluctant to vote their shares if this means a reduction in their ability to respond to market developments (by trading their shares).

But as Germany has demonstrated, the requirement that shares be deposited need not entail undue restrictions on share trading. As described by Jaap Winter, German banks usually allow transactions to be performed up to 24 hours before the meeting, despite the assumed blocking<sup>30</sup>.

### **‘Obstructive’ local protocols**

Other protocols (in addition to share blocking requirements) can also hinder the successful exercise of cross border voting. Examples of such protocols include:

- ‘Wet signature’ requirements
- Restrictions on the persons to whom proxies may be granted
- Restrictions on the number of shareholders that may be represented by the same person
- Share registration requirements
- Voting on a show of hands

As illustrated in Table 1, although the US, the UK and Germany now permit ‘electronic’ signatures on proxy appointments, proxy appointments in Italy and Japan still require a ‘wet’ signature<sup>31</sup>. In addition, the rules on proxy voting set forth in the Italian Civil Code enjoin that the same person cannot represent more than ten members at the general meeting<sup>32</sup> and permit a company’s articles of association to determine to whom proxies may be given (e.g. only to another shareholder), limit the number of shareholders that a person may represent in a more restrictive way, and even entirely waive the right to be represented at general meetings<sup>33</sup>. Nor can a proxy be granted to the directors, auditors or employees of an Italian company or of its subsidiaries<sup>34</sup>. As a consequence

---

depositing/blocking provision, shareholders would have to take their physical certificates to the meeting to prove their shareholder status. To prevent this, the depositing/blocking provisions introduced by many countries were intended to allow shareholders access to the meeting upon evidence of the deposit of their share certificates with a designated institution e.g. a bank.

<sup>30</sup> ‘The idea is that the seller then loses his voting right and the acquirer receives the voting right. In the case of stock exchange transactions, however, it is no longer possible to track the resultant shift in the voting right’ (Winter 2000, p.24).

<sup>31</sup> ‘In Italy, although the law does not contain any provisions about electronic voting at the shareholders meeting, the general provisions of the company’s legislation prohibit this voting system’ (Trevisan 2002). In Japan, the Interim Draft Revision of the Japanese Commercial Code contains a proposal to allow electronic voting of proxies and permit electronic dissemination of proxy materials (Hashimoto 2002, p.8).

<sup>32</sup> Or, in the case of companies whose shares are listed on the Italian Stock Exchange, the same person cannot represent at a meeting more than fifty shareholders if the company has a share capital not exceeding EURO 5,164,568 or more than a hundred shareholders if the company has a share capital in excess of EURO 5,164,568 but not exceeding EURO 25,822,844 or more than two hundred shareholders if the company has a share capital exceeding EURO 25,822,844 (Trevisan 2002).

<sup>33</sup> Marchetti et al. (1999, p.171).

<sup>34</sup> Until quite recently, proxies granted to company officials were also precluded under German law. However, the German Stock Corporation Act has recently been amended to allow representation by company appointed proxies and the German Corporate Governance Code recommends that all companies provide for the appointment of such a person (Noack 2002, p.6).

of these restrictions, proxy voting in Italy can often prove a tiresome and costly exercise<sup>35</sup>.

Other instances of obstructive local protocols can be found in Japan where (as described by one of the large proxy voting agencies):

'there is a great resistance to losing faith through negative votes...it used to be the case that the large commercial banks would just bin any negative votes and Japanese institutions still don't want to be seen as voting against companies'.

As a result, Japanese banks often ask clients who wish to vote to reregister their shares in their own name: an expensive and time-consuming task<sup>36</sup>.

A further disincentive to cross border voting can be found in the UK, where it is common practice (even amongst some of the largest companies) for votes to be taken on a show of hands. Not surprisingly, many foreign investors are reluctant to expend their time and effort filling in proxy forms, the voting instructions on which will never make it into the actual 'count'<sup>37</sup>.

### **Inadequate Proxy Materials**

The insufficiency or inadequacy of proxy materials can also pose a significant obstacle to successful cross border voting. For example, a common complaint amongst US investors is that – in countries such as the UK, Italy and Japan – companies are not required to distribute proxy materials to beneficial owners<sup>38</sup>. In consequence, although their custodians will usually send them a copy of the meeting notice, they may not receive the full set of materials distributed to domestic shareholders including, for

<sup>35</sup> Trevisan 2002. As described by Baums (1997, p.14), proxy voting in Italy is especially costly when professional proxy voting agents, usually attorneys or consultants, are asked to act because they often charge hundreds of dollars to attend a meeting.

<sup>36</sup> The development of JASDEC (Japan's central depository for securities) should help to alleviate this problem by obviating the need to re-register shares in order to 'save face'. As described by ISS, for those in the system, JASDEC obtains shareholder lists, including names and addresses from brokers or other nominee-type institutions and registers them in its own system. Companies' transfer agents register JASDEC as the nominal shareholder but send proxy materials to the beneficial shareholders from lists provided by JASDEC. However, until quite recently, most foreign institutions were left outside of the system because they held their shares with a Japanese custody bank, the majority of whom refused to participate in JASDEC because of concerns about high fees, client privacy, dividend retrieval and the loss of an important source of revenue – the fees they charge for transferring shares (ISS 2001, pp. 13-14).

<sup>37</sup> Of course, many British company secretaries would argue that the show of hands is merely an expeditious means of dealing with non-contentious business at a meeting. They would also point out the Chairman has a legal obligation to call a poll if the weight of proxy votes are against the result of the show of hands.

<sup>38</sup> In Germany, the Stock Corporation Act requires banks to transmit notices to all shareholders (bearer shares) and to beneficial owners of registered shares. As described by Ulrich Noack, 'this system was established to ensure that information reaches all shareholders, especially smaller investors who have deposited their shares with banks and cannot be expected to read the Federal Bulletin...but it is questionable whether a foreign intermediary is considered as a "bank" in the German sense [and] even if foreign banks receive the information there is no way to enforce contact with the shareholders as the power of German law ends at the border' (Noack 2002, pp.3-4).

example, the annual report and accounts – an essential prerequisite for an ‘informed’ voting decision.

In addition, the meeting notices and proxy forms that cross border investors do receive may suffer from inadequacies in the translation and summarization wrought by sub-custodians, global custodians and/or voting agents.

### **The inability to confirm vote execution**

Another oft-cited disincentive to cross border voting resides in the inability of investors to obtain confirmation that their vote instructions have been received and duly executed. Although they may often receive confirmation that their vote instructions have reached the global custodian, it is virtually impossible for them to audit the onward transmission of these instructions to sub-custodians and company registrars. In most countries, the company’s registrar is under no obligation to confirm the receipt and tabulation of paper proxies and, as a consequence, it is difficult for global custodians to audit the vote delivery of their sub-custodians.

Not surprisingly, the absence of robust audit procedures - by which the ultimate holder of the shares can verify whether and how those shares have been voted - generates a good deal of suspicion and resentment amongst investment managers. A striking example of this suspicion was revealed in the 1999 Inquiry into UK Vote Execution. Participants in the inquiry (a total of 176 investment institutions) were asked whether there was a mismatch between their organisations’ intended voting practices and the level of proxies actually voted. The responses to this question showed that 18% of pension scheme trustees felt that mismatches existed, as did 51% of investment managers and 60% of proxy voting advisers<sup>39</sup>.

### **Inadequate voting rights and ‘lack of uniformity across borders’**

As described in the recent Winter report, the problem that underlies many of the obstacles cited above, is the legal uncertainty over who, in cross border situations is entitled to determine how the shares are voted and how this must be realised<sup>40</sup>. Because cross border investors tend to hold their investments through a chain of securities intermediaries (global custodians, sub-custodians and central securities depositaries), they rarely appear on the company’s register of members or (in the case of bearer share systems) possess the physical share certificates. Thus, in both registered share systems and bearer share systems it is unclear how foreign shareholders, holding through chains of intermediaries, should and could provide

---

<sup>39</sup> NAPF (1999, p.31).

<sup>40</sup> N.B. The ‘uncertainty’ that the Winter report refers to does not concern the ‘legal’ entitlement to *cast* the vote which, in some countries is clearly defined (e.g. in the UK where the legal entitlement to vote is restricted to those whose names appear on a company’s register of members). It refers, rather, to the entitlement to *control* the way in which the vote is cast, which, in some countries, must be ascertained in order for a vote to be validly admitted by the company.

sufficient proof that they are entitled to control the voting right; as a consequence of which:

The position of the ultimate investor is formally not different from the securities intermediaries who are account holders higher up the chain. As account holders they may *all*, based on the applicable laws of the jurisdictions in which they hold their accounts, be entitled to exercise the rights attached to the shares held in their accounts. This leads to a potential cumulation of claims to exercise such rights and possibly conflicting, mutually exclusive rights. Currently, there is no rule or national or international law...on the basis of which it can be ascertained that the ultimate investor in a cross border situation can exercise voting rights, either directly, or through a (chain of) powers of attorney or by giving voting instructions<sup>41</sup>.

The implication of the Winter report is that – in the absence of international laws acknowledging that the entitlement to control the voting right resides with the ultimate account holders<sup>42</sup> in securities holding systems – cross border investors are *poorly positioned* to insist upon their ‘rights’ to the full and timely receipt of proxy materials and to confirmation that their voting instructions have been received and executed.

---

<sup>41</sup> Winter et al. (2002, p.15).

<sup>42</sup> The Winter Report defines the ‘ultimate account holder’ or ‘ultimate investor’ as the ‘last account holder in a securities holding system who is not himself a securities intermediary within this system’. The Report defines ‘securities intermediaries’ as International Central Securities Depositories (ICSDs), Central Securities Depositories (CSDs), global custodians and sub-custodians. Thus, in the Winter lexicon, the term ‘ultimate account holder’ would typically attach to each of the investment managers represented in our case studies.

### 3 The practice of cross border voting revealed in the ICGN study

In the literature we have just reviewed, we have encountered many obstacles to successful cross border voting. Some, but not all, of these problems are mirrored in the responses received when participants in the ICGN study were asked to describe the 'greatest obstacles to cross border voting' encountered in each of the case study countries, viz. the UK, the US, Germany, Italy and Japan. The results of this inquiry are revealed in Appendix C, which lists the greatest obstacles to cross border voting - as perceived by the case study participants. Concrete examples of these problems can also be found in Appendix D, which tracks the flow of voting materials between 25 pairs of investor-to-issuer proxy chains. In the interests of clarity and brevity, the data contained in both these appendices is summarized in the sections below.

#### Timeliness

In all the case studies involving the US issuer (USCO), none of the respondents registered any complaints about the late receipt of meeting notices, proxy forms or annual reports and accounts. In the case studies involving the German issuer (DECO), most of the participants were satisfied with the time period during which proxy materials were released although one of the voting agents complained that:

[In Germany], We believe that the timing of the release of the annual report and accounts may generally be sufficient for domestic shareholders. However, in the absence of obligation for issuers to communicate with their beneficial shareholders, the receipt of these documents by these investors can be delayed due to shorter solicitation periods. Generally, for most non-North American markets the release date of the annual report is too close to the meeting [and]...in Germany we implement a deadline of 10 days prior to the meeting in order to accommodate Market and Agents' own deadlines [as a consequence of which] there is often a limited time between the beneficial shareholder receiving the notice and needing to instruct their vote. [CASE\_19]

The same respondent observed that in the UK (in the absence of a record date for voting) it has to impose a deadline around 5 days prior to the meeting in order to validate positions and process votes to the Registrar. This respondent also noted that the relatively short notice periods adopted by UK companies are especially problematic for ADR issuers because:

ADRs are generally treated as a North American security so the expectation is that the notifications for these meetings would follow the same time scale as for an actual North American issuer. However the notifications for these meetings are generally received much closer to the meeting date than for actual North American issuers and voting cut-off is earlier. ADR administration by US agents further impinges on the time scales. [CASE\_4]

Although the focus of the case studies was restricted to ordinary shares (rather than ADRs), several investment managers held UKCO stock in both ordinary and ADR form,

one of whom provided us with an interesting commentary on the relative merits of ADRs – in terms of access to proxy materials:

The notice of meeting was timely for the ADRs but if we held only common shares, the meeting notices sent to us by these custodian banks would have been very close to the deadline...in fact, the revised proxy form arrived a day after the April 8 deadline! [CASE\_4]

In Italy, one of the voting agents complained that they did not receive the ITCO annual report and accounts until May 10 (four days after the general meeting). They were not best pleased with this as they felt that ‘the annual report and accounts should accompany the notice of meeting so the analysts can look at the directors’ and financial information’. On the other hand, the investment manager by whom they were employed told us they had ‘no issues as to the timing and release/publishing of reports’ because ‘we generally download the relevant figures/reports from the company’s website with enough time to allow suitable analysis and for votes to be processed’ [CASE\_12]. Complaints about the timing of the ITCO meeting notice were also registered by one of the global custodians and one of the investment managers (despite the fact that the notice was released more than four weeks before the actual meeting date) [CASE\_13].

In addition, one of the investment managers – with regard not just to Italy, but also to Germany and the UK - complained of the lack of a record date, the effect of which ‘results in late identification of eligible voting participants, which can result in inadequate time to distribute meeting information and receive vote instructions’.

As expected, however, it was the case studies involving the Japanese issuer (JACO), that revealed the greatest number of complaints - about the timing of meeting notices<sup>43</sup> and the concentration of meetings in the same week [see Cases 22-25 & Appendix C].

### Share-blocking

In the 12 case studies involving Italian and German issuers, only one investment manager refused to vote their shares on the grounds of share blocking [CASES 14 & 23]. Nevertheless, as revealed in Appendix C, share-blocking was the most commonly cited obstacle to ‘cross border voting’ in both these countries - despite the evidence in the Winter report that German banks usually allow deposited shares to be traded up to 24 hours before company meetings. As told to us by one of the voting agents participating in the study:

‘The market practices adopted by many intermediaries in Germany [e.g. the ‘depositing’ of shares in advance of company meetings] have led to the *perception* amongst overseas investors that this is a blocking environment.’

---

<sup>43</sup> N.B. The Interim Draft Revision of the Japanese Commercial Code proposed to lengthen the shareholder meeting notice from two weeks to four weeks (Corney & Jalowayski 2001).

This disjuncture between perception and reality may explain the decision of the one investment manager who chose not to vote his shares in Germany. On the other hand, they may simply have been resistant to any restrictions on their trading options, however brief these may have been.

### **'Obstructive' local protocols**

Of the five 'local protocols' described in Chapter 2, only one of the investment managers cited the lack of provision for 'electronic' proxy appointments as one of the 'greatest obstacles' to cross border voting in Germany, Italy and Japan (although this was not seen as a problem in the US or the UK<sup>44</sup>).

The costs incurred by the Italian restrictions on the number of persons to whom proxies can be given (and the restrictions on the number of shareholders that can be represented by the same person) were also cited as a significant obstacle to cross border voting by one of the investment managers.

In the UK, the practice of voting on a show of hands was seen as a serious obstacle to cross border voting by one of the global custodians who observed that:

'Many US investors refuse to spend time and effort making an informed vote when it is only counted 15% of the time.'

However, this particular problem did not apply to the UK issuer participating in our study, for whom poll counts are now the standard method of vote tabulation at its general meetings.

### **Inadequate proxy materials**

*Cases involving the US issuer*: As shown in Tables 2 and 3, the case studies involving the US issuer (USCO) revealed few examples of inadequate proxy materials. This was to be expected, in view of the obligations - to distribute company reports and proxy solicitation materials to beneficial owners – imposed, by the SEC, upon US companies and securities intermediaries<sup>45</sup>.

*Cases involving the UK issuer*: In the case studies involving the UK issuer (UKCO), all but one of the investment managers received the company's annual report and accounts despite the absence of any obligation that this material be distributed to beneficial owners: one obtained the report direct from the company, one pulled it direct

---

<sup>44</sup> Notwithstanding the fact that (with some noticeable exceptions e.g. UKCO), most UK companies have not introduced proprietary systems for electronic proxy appointments and the CREST system is still in its 'trailing' phase.

<sup>45</sup> Under Rule 14a-13(a) of the US Securities and Exchange Act, if a listed company knows that shares are held of 'record' in nominee name, and the company intends to solicit proxies, the company must: inquire of record holders as to the number of copies necessary to supply material to beneficial owners; supply that material to the record holders who respond to the enquiries; and pay the record holders' reasonable expenses for completing the mailing of the material to beneficial owners.

from the company's website, two obtained the report because they held ADRs (and UKCO distributes these to beneficial holders of ADRs) and one had arranged for their custodian to purchase the report from a third party supplier ('World Investor Link').

Four of the investment managers also received the full text of the UKCO meeting notice (agenda, resolutions, proxy card and Chairman's letter of invitation) although two only did so because they held ADRs. The remaining two, who shared the same global custodian, were sent a summary of the meeting notice by this custodian. The disadvantages attached to summarised meeting notices were recognized by this custodian who told us that:

"Summarised agendas are a clear area for improvement. Currently, the distribution methods that exist between our sub-custodians as well as our own electronic distribution capabilities do not cater for transmittal of complete un-abbreviated agenda resolutions" [CASE\_2]

Moreover, as one investment manager described it:

"Due to the inflexibility of our custodian's system, the meeting notice is only available for one day. Once the standing instructions are activated by our custodian, we can no longer download this information<sup>46</sup>." [CASE\_2]

*Cases involving the German issuer* : The annual report and accounts of the German issuer (DECO) were received by two of the investment managers, downloaded in both cases from the company's website. One received electronic copies of the accounts (but not the annual report) from its custodian/voting agents. The other two investment managers appear to have received neither the accounts nor the report. With regard to the meeting notice, three of the investment managers received full text, English language versions of the agenda, resolutions and proxy cards whilst the other two had to make do with the versions summarised and translated by their custodians and voting agents.

*Cases involving the Italian issuer* : Only one of the investment managers appears to have received the annual report of the Italian issuer (ITCO) prior to the general meeting (by pulling it from the company's website). Another received an electronic copy of the accounts from its custodian/voting agents but not the annual report. As described to us by one of these custodians (and with reference not just to Italy but to all the countries in our study):

---

<sup>46</sup> Aware of this problem, the custodian was planning to introduce a (proprietary) web based delivery and vote collection capability.

“In most cases, annual reports are only available in hard copy, making collection and distribution too expensive and time consuming. If electronic information was readily available (or preferably, if a Web URL directing interested parties to a company hosted site containing such information was available), we believe market practices would rapidly evolve to include such information. [Hence] we believe the timing of report information would in most cases be acceptable, if the method of delivery could be changed.” [CASE\_14]

With regard to the meeting notice, only one of the investment managers claimed to have received a full text, English language version of the ITCO meeting notice (agenda and resolutions); the others had to content themselves with the versions summarised and translated by their custodians and voting agents.

*Cases involving the Japanese issuer* : None of the investment managers appear to have received the annual report of the Japanese issuer prior to the general meeting although one received an electronic copy of the accounts from its custodian/voting agents. By way of explanation, both of the voting agents in our study informed us that they did not receive the JACO annual report until June 27 (i.e. a day after the general meeting). With regard to the meeting notice, only one of the investment managers received full text, English language versions of the JACO agenda, resolutions and proxy cards; the others had to rely on the versions summarised and translated by their custodians and voting agents.

**Table 2:** Receipt of Annual Report and Accounts

	Received	Format and source(s)
UKCO-IM1	Yes	Pulled from company website
UKCO-IM2	Yes	Hard copy direct from company
UKCO-IM3	Yes	Hard copy through custodian's purchase from World Investor Link
UKCO-IM4	Yes	Hard copy ADP ('and only because we held ADRs')
UKCO-IM5	Yes	Hard copy from ADP
UKCO-IM6	No	NA
USCO-IM1	Yes	Pulled from company website
USCO-IM2	No	NA
USCO-IM4	Yes	Hard copy from ADP
USCO-IM5	Yes	Hard copy from ADP
USCO-IM6	Yes	Hard copy from ADP
DECO-IM1	Yes	Pulled from company website
DECO-IM2	No	NA
DECO-IM4	Accounts only	Electronic copies from custodian and voting agent
DECO-IM5	Yes	Link to report on company website sent to them by voting agent
DECO-IM6	No	NA
ITCO-IM1	Yes	Pulled from company website
ITCO-IM2	No	NA
ITCO-IM4	Accounts only	Electronic copies from custodian and voting agent
ITCO-IM5	Yes (but late)	Electronic copy from voting agent (who received it four days after the AGM)
ITCO-IM6	No	NA
JACO-IM2	No	NA
JACO-IM4	Accounts only	Electronic copies from custodian and voting agent
JACO-IM5	No	NA
JACO-IM6	No	NA

Notes:

NA = Not Applicable

Source:

ICGN Cross Border Proxy Voting Study 2002

**Table 3:** Receipt of meeting notices

	Length	Format and source(s)
UKCO-IM1	Full text	Electronic copy from voting agent
UKCO-IM2	Summarised	Electronic copy from custodian
UKCO-IM3	Full text	Hard copy from custodian
UKCO-IM4	Full text	Electronic copies from custodian and voting agent (for ordinary shares). <i>But IM4 also received a full text hard copy from ADP (because of its holdings of ADRs).</i>
UKCO-IM5	Full text	Electronic copy from voting agent (for ordinary shares). <i>But IM5 also received a full text hard copy from ADP (because of its holdings of ADRs).</i>
UKCO-IM6	Summarised	Electronic copy from custodian
USCO-IM1	Full text	Hard copy from ADP
USCO-IM2	Summarised	Electronic copy from voting agent
USCO-IM4	Full text	Hard copy from ADP
USCO-IM5	Full text	Hard copy from ADP
USCO-IM6	Full text	Hard copy from ADP
DECO-IM1	Full text	Translated electronic copy from voting agent
DECO-IM2	Full text	Translated electronic copy from custodian. <i>But IM2 also received a translated, full text, hard copy from Georgeson Shareholder.</i>
DECO-IM4	Summarised	Translated electronic copies from custodian and voting agent.
DECO-IM5	Full text	Translated electronic copy from voting agent
DECO-IM6	Summarised	Translated electronic copies from custodian and voting agent.
ITCO-IM1	Full text	Translated electronic copy from voting agent
ITCO-IM2	Summarised	Translated electronic copy from custodian.
ITCO-IM4	Summarised	Translated electronic copies from custodian and voting agent.
ITCO-IM5	Summarised	Translated electronic copy from voting agent.
ITCO-IM6	Summarised	Translated electronic copy from custodian
JACO-IM2	Summarised	Translated electronic copy from custodian.
JACO-IM4	Summarised	Translated electronic copies from custodian and voting agent.
JACO-IM5	Full text	Translated electronic copy from voting agent.
JACO-IM6	Summarised	Translated electronic copy from voting agent.

Source:

ICGN Cross Border Proxy Voting Study 2002

## Inability to confirm vote execution

To gauge the extent to which investment managers were attempting to monitor the execution of vote instructions by their custodial intermediaries, we put to them the following question: “*Over the past three years, have you asked your custodians/voting agents to report on your execution of proxy votes?*” Of the six investment managers in our study, one did not reply and one indicated that they had not asked for any such reports. But the other four managers each suggested that they ‘regularly’ asked for reports on vote execution. The detail requested in these reports was described to us by one manager as follows:

We are in the process of getting [our voting agent] to report on where we have missed deadlines through late notification of the meetings involved. We have also requested that they start highlighting those stocks in our portfolio where they do not process votes.

Unfortunately, the evidence from the case studies suggests that, despite the use of electronic instruction mediums and dedicated proxy voting agents, investment managers still find it very difficult to audit the transmission of their vote instructions to company registrars/stock transfer agents.

As shown in Table 4, the auditing of voting instructions was easiest in those cases involving the US issuer. Here, the use of a common mailing/vote processing agent (ADP) has facilitated the introduction of electronic instruction mediums – not just between the investment manager and the voting agent but also between the voting agent and the company’s registrar. Indeed, the only case in which such auditing may not have been possible was where the investment manager held shares through two custodians who had not contracted with ADP<sup>47</sup>.

In the UK, Germany and Japan, vote instructions were frequently sent to custodians/voting agents via an electronic link (either web based or through some other proprietary medium) but in many cases, the investment manager did not receive an ‘automatic’ confirmation of receipt. More importantly, the investment managers were rarely in a position to audit the onward transmission of these instructions e.g. from global custodian to sub-custodian (or from sub-custodian to registrar). As described to us by one global custodian:

“Confirmation is based on exception processing: sub-custodians are contractually bound to deliver information to issuers/agents and only contact us if the information was NOT delivered/accepted in a timely manner. Similarly, we will only ‘negatively confirm’. We did not receive notice of failed votes for these (or any) votes in 2002.” [CASE-21]

---

<sup>47</sup> In both instances, vote instructions had to be sent to the custodians by mail (without a corresponding delivery receipt).

In the UK, the introduction of the CREST proxy voting portal – should it prove successful – will ease some of the obstacles to straight through auditing<sup>48</sup> but it remains to be seen whether central securities depositories in other countries will follow their example.

**Table 4:** Confirmation of vote instructions by custodians, voting agents and registrars

	Instructions to custodians/voting agents		Instructions to registrar/transfer agent	
	Delivery	Confirmation	Delivery	Confirmation
UKCO-IM1	Electronic link	Monthly email report	Not stated	Not stated
UKCO-IM2	Electronic link	None	Courier	None
UKCO-IM3	Fax	None	Courier	None
UKCO-IM4	Fax	None	Courier	None
UKCO-IM5	Electronic link	Electronic link	Courier	None
UKCO-IM6	Fax	None	Courier	None
USCO-IM1	Electronic link	Monthly email report	Electronic vote file	Electronic
USCO-IM2	Standing instructions	NA	Electronic vote file	Electronic
USCO-IM4 <sup>a</sup>	Electronic link	Electronic link	Courier	None
USCO-IM4 <sup>a</sup>	Mail	None	Not stated	Not stated
USCO-IM5	Electronic link	Electronic link	Electronic vote file	Electronic
USCO-IM6	Electronic link	Electronic link	Electronic vote file	Electronic
DECO-IM1	Electronic link	Monthly email report	Not stated	Not stated
DECO-IM2	Electronic link	None	Not stated <sup>b</sup>	Not stated
DECO-IM4	None sent <sup>c</sup>	NA	NA	NA
DECO-IM5	Electronic link	Electronic link	Not stated	Not stated
DECO-IM6	Fax	None	Not stated <sup>b</sup>	Not stated
ITCO-IM1	Electronic link	Quarterly email report	Not stated	Not stated
ITCO-IM2	Electronic link	None	Not stated <sup>b</sup>	Not stated
ITCO-IM4	None sent <sup>c</sup>	NA	NA	NA
ITCO-IM5	Electronic link	Not stated	Not stated	Not stated
ITCO-IM6	None sent <sup>d</sup>	NA	NA	NA
JACO-IM2	Standing instructions	NA	Not stated <sup>b</sup>	Not stated
JACO-IM4	Standing instructions	NA	Courier	Not stated
JACO-IM5	Electronic link	Electronic link	Not stated	Not stated
JACO-IM6	Standing instructions	NA	Courier	Not stated

**Notes:**

<sup>a</sup> IM4 sent voting instructions in respect of USCO through VA2 (via electronic link) and also through GC5 and GC6 (via mail)

<sup>b</sup> The global custodian sent the vote instructions to its sub-custodian by Tested Telex but did not specify the format by which the sub-custodian delivers these instructions to the issuer’s registrar.

<sup>c</sup> IM4 did not return any vote instructions “because of shareblocking” (they did not elaborate on this).

<sup>d</sup> IM6 did not return any vote instructions “because of lending activity” (they did not elaborate on this).

<sup>48</sup> In addition to straight through auditing, the advantages of the CREST system were also noted by one of the voting agents in our study: ‘The CREST electronic voting portal will enable us to reduce voting cut off times to a minimum and eliminate manual proxy card completion’.

## Inadequate voting rights and lack of uniformity across borders

As described in Chapter 2, from the perspective of the 'Expert Group on Cross Border Voting in Europe', the obstacles addressed above (e.g. late receipt of proxy materials or the lack of 'straight through' vote processing and auditing) may require the adoption of common international standards because:

“[Although] modern information and communication technology will be essential in providing for efficient systems of shareholder information, communication and voting...the underlying problems...cannot be resolved by modern technology as such but require regulation. Only when these problems are solved will investors, both national and international, be able to reap the full fruit of modern technology.”<sup>49</sup>

Of course, modern technology and market forces have lowered *some* of the obstacles to cross border voting. As indicated in the previous section, this is particularly noticeable in respect of the proxy chains linking investment managers to global custodians. These chains have been streamlined by the consolidation of the global custody industry and the development of 'global' proxy voting agents<sup>50</sup>. The effects of these processes are visible in the graphs attached to the case studies, which show the extent to which the proxy voting business has been outsourced to a small handful of global proxy voting agents, whose success is dependent on their ability to transmit proxy materials (and proxy votes) quickly, cheaply and reliably.

---

<sup>49</sup> Winter 2002, p.10.

<sup>50</sup> Over the past ten years the leading players in the custody business have rapidly consolidated, with the top 10 global custodians now controlling 81 per cent of the estimated \$46 trillion in assets held by the industry (see Table 5). And, as the market for global custodians has concentrated, so too has the market for sub-custodians (see Figure 8).

**Table 5:** Top 10 custodians by assets (2002)

Bank	Asset (USD bn)	Market share (%)
JPMorgan	6700	14.6
Bank of New York	6613	14.4
State Street	6200	13.5
Citibank N.A.	5400	11.8
Deutsche Bank	3661	8.0
Mellon Group	2800	6.1
BNP Paribas	1783	3.9
Northern Trust	1720	3.7
SIS Segaintersettle	1200	2.6
HSBC Bank plc	1060	2.3

Source: [www.globalcustody.net](http://www.globalcustody.net)

**Figure 8:** The number of sub-custodians in major markets, 1997-2001

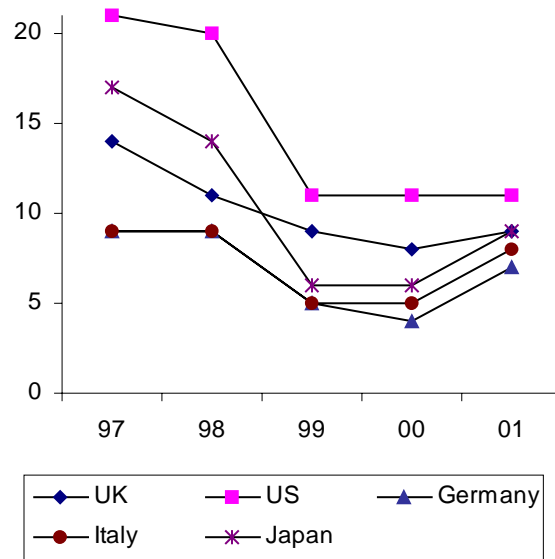

Source: Financial Times (July 5, 2002)

Nevertheless, technology and market forces cannot be relied upon to solve *all* the obstacles to cross border voting. Take, for example, voting on a show of hands in the UK, share-blocking in Italy, the concentration of meetings in Japan, the hard copy delivery of poll cards to registrars (in the absence of an electronic voting interface): these are all problems that can only be resolved through a reform of domestic law<sup>51</sup> and market practice. International bodies, such as the ICGN, will continue to monitor these problems and urge their swift resolution; but the size and complexity of this undertaking should not be underestimated.

<sup>51</sup> For a description of some of the proposed changes to domestic regulation see Bates & Stapledon (2002).

## References

- Arnold, C. 1999. 'Voting Abroad: Practical Experiences' in Baums, T. and Wymeersch, E. (eds.) *Shareholder Voting Rights and Practices in Europe and the United States*. The Hague: Kluwer Law International.
- Bates, J. and G. Stapledon (2002). 'Reducing the Costs of Proxy Voting' in McCahery et. al. *Corporate Governance Regimes and Diversity*. Oxford: OUP.
- Baums, T. 1997. 'Shareholder Representation and Proxy Voting in the European Union: A Comparative Study' . Paper presented at the Conference on Comparative Corporate Governance, Max-Planck-Institut für Ausländisches und Internationales Privatrecht, Hamburg, May 15-17.
- Baums, T. and Schmitz, R. 1999. 'Shareholder Voting in Germany'. Mimeo.
- Baums, T. and Wymeersch, E. 1999. *Shareholder Voting Rights and Practices in Europe and the United States*. The Hague: Kluwer Law International.
- Comey, C. and S. Jalowayski (2001). 'Commercial Code Reform'. *Japan Inc Magazine*.
- Georgeson Shareholder Communications Inc 2001. 'Cross Border Proxy Solicitation'. *Investor Relations Guide* No. 6.
- Georgeson Shareholder Communications Inc., "Annual Corporate Governance Review 2002 -- Shareholder Proposals and Proxy Contests," available at [www.georgesonshareholder.com](http://www.georgesonshareholder.com).
- Hashimoto, M. (2002). 'Commercial Code Revisions: Promoting the Evolution of Japanese Companies'. *Nomura Research Institute Papers*, No. 48.
- ICI 2000. 'Global Corporate Governance Issues for Mutual Funds' . Washington DC: Investment Company Institute.
- IMF 2001. *International Financial Statistics Yearbook*. Geneva: International Monetary Fund.
- ISS 2001. *The ISS Global Proxy Voting Manual - Japan*. Institutional Shareholder Services.
- Mallin, C. 2001. 'Cross Proxy Voting (A Survey of ICGN Members)' . Birmingham: University of Birmingham.
- Manifest 2002. 'Proxy Poll Votes 2002: An analysis of proxy voting trends at UK shareholder meetings' . Witham: The Manifest Voting Agency Ltd.
- Marchetti, P., et al. 1999. 'Italy' in Baums, T. and Wymeersch, E. (eds.) *Shareholder Voting Rights and Practices in Europe and the United States*. The Hague: Kluwer Law International.
- NAPF 1999. 'Report of the Committee of Inquiry into UK Vote Execution'. London: National Association of Pension Funds.
- Noack, U. 2002. 'Notes for the Second Meeting of the Cross Border Voting Group'. University of Dusseldorf.
- ONS 2002. 'Share Ownership 2001'. London: Office of National Statistics.

PIRC 1999. 'Proxy Voting Trends 1999: Third Survey of Proxy Voting Levels'. London: Pensions & Investment Research Consultants.

Trevisan, D. 2002. 'Italian Proxy Voting System: General Overview About Shareholders Meetings'. Milan: Trevisan & Partners.

Warnock, F. 2001. 'Home Bias and High Turnover Reconsidered (International Finance Discussion Paper, No. 702)'. Washington, DC: U.S. Federal Reserve Board.

Wilcox, John C., 'Cross-Border Proxy Voting -- Globalization Hits a Speedbump,' in *Insights*, Volume 14, Number 12, December 2000 (Aspen Publishers, Inc., Gaithersburg, MD, USA).

Winter, J. 2000. 'Cross Border Voting in Europe'. Paper for the Siena Conference on the impact of securities markets on companies and their regulation, 30-31 March.

Winter, J., et al. 2002. 'Cross Border Voting in Europe'. The Hague: Dutch Ministry of Justice.

## Appendix A

### Project Methodology

The steps required to complete the case studies are summarised in the table below and a detailed description of each step is contained in the following section.

#### Outline of Steps Required to Complete Phase 1

Step	Action
1	Scope the project
2	Solicit funding
3	Contract with independent research team
4	Negotiate participation of issuers and investors
5	Obtain details of custodians/voting agents
6	Administer questionnaire for each participant investor
7	Administer questionnaire for each named global custodian
8	Administer questionnaire for each named voting agent
9	Draft interim report for ICGN annual conference in July
10	Summarise proxy voting law and practice in each jurisdiction
11	Analyse data from questionnaires
12	Draft final (anonymised) report

#### Scope the project

To control costs and ensure the timely completion of the study, it was decided to limit the case studies to five global issuers and six institutional investors

#### Solicit funding

On April 2, 2002, the ICGN Board of Governors approved a motion to fund the first phase of the study. Additional funds were received from the following ICGN members: BP plc, Hermes Investment Management Ltd, Investment Company Institute, Lloyds-TSB Registrars and TIAA-CREF Institute.

#### Contract with independent research team

On April 17, 2002 the ICGN engaged Institutional Design Limited (IDL) to work on the first phase of the study. To facilitate their investigations, the ICGN agreed to procure the authority and consent of the participants in the Study to release the information necessary for IDL to conduct the Study.

#### Negotiate participation of issuers and investors

During the months of April and May 2002, the Chairman of the Cross Border Voting Practices Committee (with the support of IDL) actively solicited the participation in the study of a range of global issuers and institutional investors. By the end of May, the team had secured the commitments of five global issuers (one each from the UK, the US, Italy, Germany and Japan) and six global investors (three from the UK and three from the US).

### **Obtain details of custodians/voting agents**

IDL prepared a template for use in collating the information necessary to map the names and identities of the custodians and voting agents used by the participant institutional investors. Each participant was also requested to solicit the support and cooperation of the contacts named in their completed templates. To facilitate this request, IDL prepared a pro-forma letter for distribution (by the seven participants) to each of the 3rd parties involved in their cross border proxy voting processes. Follow up calls and emails were made to each of the participant institutional investors requesting the prompt return of their completed templates.

### **Administer tailored questionnaire for each participant institutional investor**

Upon receiving the details of the investors' custodians and voting agents, IDL then drafted questionnaires to be completed by each of the participating institutional investors. Although the same questions were asked of the six participants, the extent of the required data was tailored to fit the custodial/voting agent profile of each participant (see Appendix E for a copy of this questionnaire).

### **Administer generic questionnaire for each named global custodian**

To mirror the questionnaire administered to the participant institutional investors, IDL drafted a questionnaire to be completed by each of the global custodians (the contact details of whom were provided by the six participating institutional investors). This questionnaire was drafted in such a way as to mirror the questionnaire administered to the participating institutional investors.

### **Administer generic questionnaire for each named voting agent**

Using the information provided by the participant institutional investors, IDL also drafted a questionnaire to be completed by a small group of voting agents. As with the instrument administered to the global custodians, this questionnaire was designed to mirror the questionnaires applied to the institutional investors.

### **Draft interim report for ICGN annual conference in July**

IDL drafted an interim report for consideration (by the Chairman of the Committee on Cross Border Voting Practices) at the ICGN's annual conference on July 10, 2002.

### **Summarise proxy voting law and practice in each jurisdiction**

To contextualise the results of the audit, the research team analysed the laws and practices regulating proxy voting in each of the jurisdictions covered by the study.

### **Analyse data from questionnaires**

Upon receipt of completed questionnaires from each of the participating investors, custodians and voting agents, IDL began the process of data analysis.

### **Draft final (anonymised) report**

The report of which this appendix is a part represents the conclusion of Phase 1 of the case study project.

## **Appendix B**

### **Case Study Participants**

N.B. To preserve the confidentiality of the responses provided to us in the case studies (by the global custodians, voting agents and investment managers), we have used 'case identifiers' throughout the report. If you are a member of one of the institutions named below and would like to know your case identifier, please contact Institutional Design).

#### **Issuers**

BP plc  
The Coca-Cola Company  
Unicredito Italiano S.p.A.  
Allianz AG  
Nikko Cordial Corporation

#### **Investment managers**

Friends Ivory & Sime plc  
Hermes Investment Management Ltd  
Standard Life Investments Ltd  
Fidelity Investments Management Ltd  
CALPERS  
TIAA-CREF Institute

#### **Proxy voting agents**

Institutional Shareholder Services  
ADP Investor Communications

#### **Global custodians**

JP Morgan Chase & Co.  
State Street Corporation  
HSBC Ltd  
Citibank Global Securities Services

#### **Proxy solicitors**

Georgeson Shareholder Communications

## Appendix C

### Greatest obstacles to cross border proxy voting (as perceived by case study participants)

In General	
VA2	The lack of cross border generic standards leads to non-systematic exceptions. There are no standards covering levels of communication to the different types of shareholders e.g. registered, beneficial, or the indigenous types of shares issued e.g. registered, bearer. Also there is a general level of ignorance regarding the different market practices amongst the global asset management community, plus there is no standard language for documents.
IM5	The greatest obstacle we have found to cross border voting is the confirmation that a company has accepted a late vote instruction, when applicable.

In the UK	
VA2	The lack of regulation around a Voting Entitlement Date.
GC4	Lack of a record date results in late identification of eligible voting participants, which can result in inadequate time to distribute meeting information and receive vote instructions.
VA2	No obligation to communicate with all investors leads to disenfranchisement of beneficial shareholders unless they pay to participate.
VA1	Lack of a universal means of distributing materials and executing votes.
GC1	Show of hands vs. calling a poll. Many US investors refuse to spend time and effort making an informed vote when it is only counted 15% of the time.
IM4	Voting confirmation, lack of internet-based global voting service with record-keeping capabilities.
IM3	Receiving complete documentation in a reasonable amount of time.

In the US	
GC1	Limited capability to deliver electronic information (including financial statements) to cross border investors.
GC9	Getting proxy information to the beneficial owner, no matter how many banks it is registered through, in a timely fashion.

<b>In Germany</b>	
VA2	Market practices adopted by many Intermediaries have lead to the perception amongst overseas investors that this is a blocking market.
VA2	Different procedures are required for bearer and registered shares.
VA2	No obligation to communicate with all investors leads to disenfranchisement of beneficial shareholders unless they pay to participate.
VA1	Share-blocking
IM6	Share-blocking
GC1	Share-blocking
IM4	Share-blocking
IM4	Lack of disclosure
IM4	Lack of internet-based global voting service with record-keeping capabilities.
GC4	Lack of a record date results in late identification of eligible voting participants, which can result in inadequate time to distribute meeting information and receive vote instructions.
IM3	Receiving notification and documentation.
IM3	Share-blocking
IM3	Lack of client-demand
IM2	Share-blocking

<b>In Italy</b>	
VA2	Share blocking and the lack of regulation around a Voting Entitlement Date.
VA2	No obligation to communicate with all investors leads to disenfranchisement of beneficial shareholders unless they pay to participate.
VA1	Share blocking
IM6	Share blocking
GC1	Share blocking
IM4	Share-blocking
IM4	Lack of disclosure
IM4	Lack of internet-based global voting service with record-keeping capabilities.
GC4	Lack of a record date results in late identification of eligible voting participants, which can result in inadequate time to distribute meeting information and receive vote instructions.
IM3	Receiving notification and documentation.
IM3	Lack of client-demand
FIS	Cost - fees for voting are frequently too high to be of benefit to the funds involved.
IM2	Late release of the full agenda.
IM2	Share blocking

<b>In Japan</b>	
VA2	Short solicitation period coupled with the language of notification.
VA2	The timing of the majority of Japanese AGMs.
VA2	No obligation to communicate with all investors leads to disenfranchisement of beneficial shareholders unless they pay to participate.
VA1	Short time frame between release of materials and the voting deadline.
IM3	Concentration of meetings over a few days.
GC1	"Meeting Week" and short time-frames for collection and translation of material
IM4	Concentration of meeting dates
IM4	Lack of disclosure
IM4	Lack of internet-based global voting service with record-keeping capabilities.
GC4	Scheduling of virtually all shareholder meetings within a 3 day time frame.
GC4	Late release of agenda information in local language, requiring English translation.
IM6	Receiving notification and documentation.
IM6	Highly condensed voting season is a major barrier to considered voting and any kind of corporate engagement.
IM6	Lack of client demand.
IM2	Schedule of AGMs

## Appendix D

### Case 1 (UK issuer)

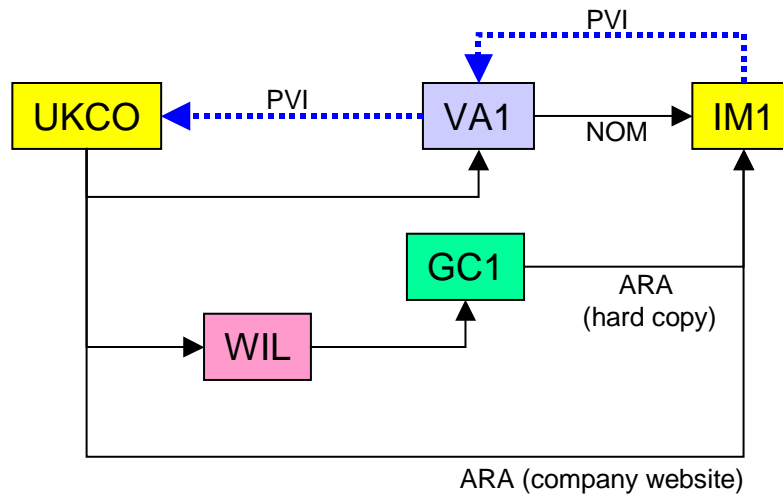

#### Holding pattern

IM1 held shares in UKCO through 6 global custodians: GC1, GC7, GC8, GC2, GC9 and GC10. These custodians were not directly involved in the proxy voting process (with the exception of GC1, who sent IM1 a hard copy of the annual report and accounts) because, in each case, VA1 performed the role of proxy voting agent.

#### The receipt of annual reports

IM1 received – from GC1 - a hard copy of the UKCO annual report and accounts (ARA) on March 15. GC1 did not indicate the date on which they themselves received the ARA but they explained that: “We do not receive Financial Statements for onward distribution. In the UK, reports and accounts are purchased from a 3rd party supplier (World Investor Link) for clients who require them”. Further conversations with GC1 revealed that big clients such as IM1 have usually lodged a standing order for GC1 to supply them with the ARA. Neither IM1 nor GC1 felt the need for UKCO to release the ARA “any earlier”. As IM1 explained: “We generally download the relevant figures / reports from the company’s website. This is done with enough time to allow suitable analysis and for votes to be processed but no record is kept as to exact dates. In this instance we have no issues as to the timing and release/publishing of reports”.

#### The receipt of meeting notices (agenda, resolutions and proxy cards)

VA1 claim to have received the UKCO notice of meeting on March 16 (in hard copy and fax, unabridged) and the proxy cards on March 19 (via data feed and fax, unabridged). But IM1 claims it did not receive a copy of these materials (via electronic link, unabridged) from VA1 until April 1. But this still left 17 days before the AGM and neither IM1 nor VA1 felt the need for UKCO to release these materials any earlier.

#### The return of proxy instructions to custodians/voting agents

IM1 sent all their voting instructions in respect of UKCO to VA1 (via electronic link) on April 2. Just over a month later (May 3) IM1 received confirmation from VA1 (via monthly email report) that VA1 had received and acted upon their vote instructions.

#### The execution of proxy votes by custodians/voting agents

VA1 did not answer the following questions: To whom were these instructions passed? On what date? In what format? Did you obtain confirmation from the Issuer’s registrar/transfer agent that they had received the proxy cards delivered to them?

## Case 2 (UK issuer)

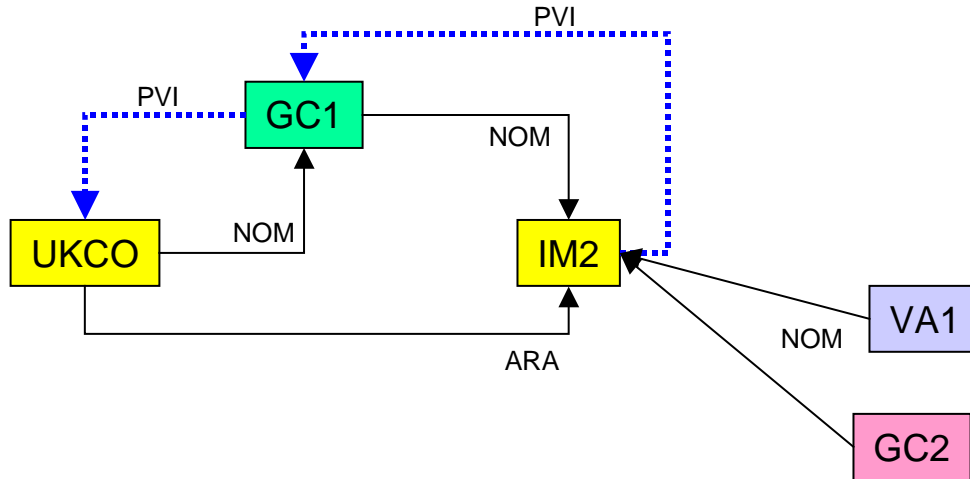

### Holding pattern

IM2 held shares in UKCO through one global custodian (GC1).

### The receipt of annual reports

IM2 indicated that, although they did not receive the annual report and accounts (ARA) from their custodian (GC1), they did obtain a hard copy direct from the company in 'mid March'. Neither IM2, nor GC1, felt the need for UKCO to release the ARA "any earlier".

### The receipt of meeting notices (agenda, resolutions and proxy cards)

GC1 received UKCO's notice of meeting and proxy form on March 18 (in hard copy, unabridged). In turn, IM2 claim to have received these materials from GC1 in 'mid March' via GC1's proprietary electronic link. Neither IM2 nor GC1 felt the need for UKCO to release these materials any earlier. IM2 did note however that: "Due to the inflexibility of GC1's system, this information is only available for one day. Once the standing instructions are activated by GC1, we can no longer download this information." IM2 also note that the proprietary link used by GC1 only shows the resolutions and not the full text of the notice of meeting. This is something that GC1 themselves acknowledged when they told us that: "Summarised agendas are clear area for improvement. Currently the distribution methods that exist between our sub-custodians as well as our own electronic distribution capabilities to clients do not cater for transmittal of complete un-abbreviated agenda resolutions." Fortunately, GC1 is not the only source from which IM2 receives UKCO's proxy voting materials. It also receives these materials from VA1 and from the GC2 (who although they act as the custodian of another client also provide IM2 with these materials).

### The return of proxy instructions to custodians/voting agents

IM2 sent all their voting instructions in respect of UKCO to GC1 (via electronic link) on April 4 but they did not receive any confirmation from GC1 that their instructions had been received and acted upon. GC1 explained their practice as follows: "Confirmation is based on exception processing – sub-custodians are contractually bound to deliver information to issuers/agents and only contact GC1 if the information was NOT delivered/accepted in a timely manner. Similarly GC1 will only 'negatively confirm'. We did not receive notice of failed votes for these (or any) votes in 2002."

### The execution of proxy votes by custodians/voting agents

GC1 then couriered the executed proxy forms to the UKCO registrar on April 15 but did not obtain a receipt from the registrar acknowledging the delivery of these forms.

### Case 3 (UK issuer)

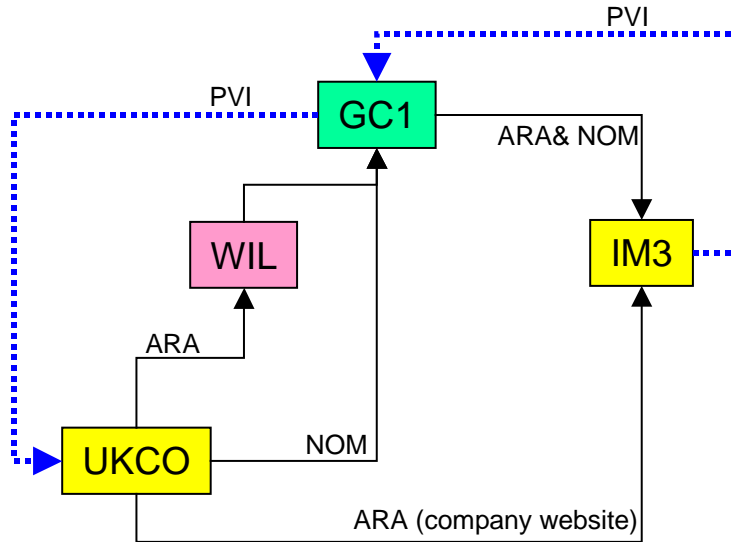

#### Holding pattern

IM3 held shares in UKCO through one global custodian (GC1).

#### The receipt of annual reports

IM3 received a hard copy of the annual report and accounts (ARA) from GC1 on March 18. GC1 explained that: “We do not receive Financial Statements for onward distribution. In the UK, reports and accounts are purchased from a 3rd party supplier (World Investor Link) for clients who require them”. Further conversations with GC1 revealed that big clients such as IM3 have usually lodged a standing order for GC1 to supply them with the ARA. IM3 also downloaded a copy direct from the company’s website. Neither IM3 nor GC1 felt that UKCO should release the ARA any earlier. On the contrary, IM3 indicated that “the company has a very good record on these issues”.

#### The receipt of meeting notices (agenda, resolutions and proxy cards)

GC1 received UKCO’s notice of meeting and proxy form on March 18 (in hard copy, unabridged) and delivered them (also in hard copy) to IM3 on the same day (along with the annual report and accounts). Neither IM3 nor GC1 felt the need for UKCO to release the notice of meeting and proxy forms any earlier.

#### The return of proxy instructions to custodians/voting agents

IM3 faxed all their voting instructions in respect of UKCO to GC1 on April 12 but they did not receive any confirmation from GC1 that their instructions had been received and acted upon. GC1 explained their practice as follows: “Confirmation is based on exception processing – sub-custodians are contractually bound to deliver information to issuers/agents and only contact GC1 if the information was NOT delivered/accepted in a timely manner. Similarly GC1 will only ‘negatively confirm’. We did not receive notice of failed votes for these (or any) votes in 2002.”

#### The execution of proxy instructions by custodians/voting agents

GC1 then couriered the executed proxy forms to the UKCO registrar on April 15 but did not obtain a receipt from the registrar acknowledging the delivery of these forms.

### Case 4 (UK issuer)

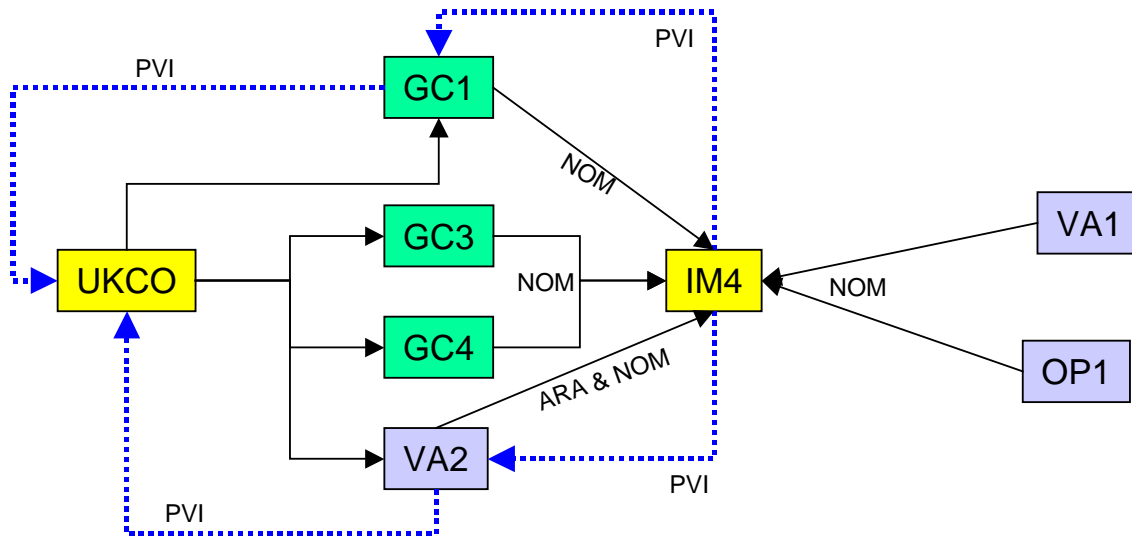

#### Holding pattern

IM4 held shares in UKCO through three global custodians: GC1, GC3 and GC4. For the shares held through GC3 and GC4, VA2 performed the role of proxy voting agent.

#### The receipt of annual reports

IM4 obtained a hard copy of the UKCO annual report and accounts (ARA) – from VA2 on March 26, which was “soon enough” but they received the ARA “only because we held ADRs” i.e. they did not receive the ARA from any of their custodial banks. Not surprisingly, the custodial banks did not indicate a need for UKCO to publish the ARA any earlier but VA2 commented as follows: “We believe the timing of the release of the annual reports may generally be sufficient for registered shareholders. However, in the absence of obligation for issuers to communicate with their beneficial shareholders, the receipt of these documents by these investors can be delayed due to shorter solicitation periods. Generally, for most non-North American markets, the release date of the annual report is too close to the meeting.”

#### The receipt of meeting notices (agenda, resolutions and proxy cards)

Because IM4 held UKCO ADRs as well as UKCO ordinary shares, it received an electronic notice of the UKCO meeting date from VA2 on March 11 containing just the agenda and proxy form. It also received a (full text) hard copy of the notice of meeting from VA2 on March 26 (posted by VA2 on March 22). In respect of its holdings of UKCO ordinary shares, IM4 received an abridged meeting notice (i.e. resolutions and proxy form only and not the full text) via PDF email attachment from GC3 on March 28 and from GC4 on April 9. It also received an abridged meeting notice via electronic link from GC1 on April 15. In view of these dates, IM4 claim that “the notice of meeting was timely for the ADRs but if we held only common shares, the meeting notices sent to us by these custodian banks would have been very close to the deadlines [imposed by IM4]...in fact, the revised GC4 proxy form arrived a day after the April 8 deadline!”. This deadline was imposed by IM4 in order to meet the deadlines of their voting Agent (VA2). As VA2 explained to us: “In the UK, the Registrar requires the vote 48 hours prior to the meeting, but in the absence of a Record Date for voting, we have to impose a deadline around 5 days prior to the meeting in order to validate positions and process votes (physically) to the Registrar”. VA2 also observed that the short notice periods are particularly problematic for companies, like UKCO, who have sponsored ADR programmes. As they put it: “ADRs are generally treated as a North American security so the expectation is that the notifications for these meetings would follow the same time scale as for an actual North American issuer. However the notifications for these meetings are generally received much closer to the meeting date than for actual North American issuers and voting cut-off is earlier. ADR

administration required by US agents further impinges on the time scales.” IM4 also indicated that they received the UKCO meeting notice from two other sources: VA1 and OP1.

**The return of proxy instructions to custodians/voting agents**

IM4 voted their UKCO ADRs via VA2’s electronic voting interface on April 3 and received immediate electronic confirmation from VA2 that their vote instructions had been received. In respect of their UKCO ordinary shares held through GC3 and GC4, IM4 faxed its vote instructions to VA2 (appointed as voting agent in respect of these shares) on April 9 but claim to have received no receipt confirmation from VA2. On this subject, VA2 observes that: “For our clients voting via fax for non-North American securities, they will receive a Daily Activity Report (if requested) reflecting the receipt of the vote instruction by VA2”. In respect of the UKCO ordinary shares held through GC1, voting instructions were faxed to GC1 on April 9 but GC1 did not provide confirmation back to IM4. GC1 explained their practice as follows: “Confirmation is based on exception processing – sub-custodians are contractually bound to deliver information to issuers/agents and only contact GC1 if the information was NOT delivered/accepted in a timely manner. Similarly GC1 will only ‘negatively confirm’. We did not receive notice of failed votes for these (or any) votes in 2002.”

**The execution of proxy instructions by custodians/voting agents**

With regard to the UKCO ADRS, VA2 note that vote instructions were sent to the tabulator via electronic vote file and hard copy beginning April 3 and concluding on April 12, in line with market practice. In addition, VA2 monitors the vote file to ensure pick up by the tabulators. With regard to the UKCO ordinary shares, VA2 observe that “in our capacity as UK agent, we submitted hard copy proxy cards to the Registrar on April 9”. But VA2 did not obtain a receipt from the registrar acknowledging the delivery of these forms (because “UK registrars do not provide confirmation of receipt of the proxy cards”). As for GC1, it couriered its proxy forms to the UKCO registrar on April 15 and (presumably for the same reason) did not obtain a receipt from the registrar acknowledging the delivery of these forms.

### Case 5 (UK issuer)

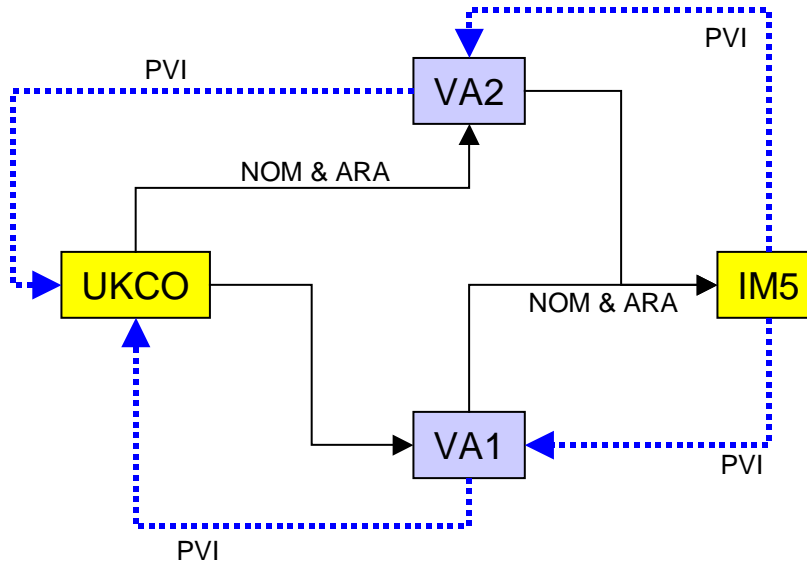

#### Holding pattern

IM5 held shares in UKCO through one global custodian (GC4 Bank). This custodian was not directly involved in the voting process because the role of proxy voting agent was assigned to VA2 and VA1.

#### The receipt of annual reports

IM5 were sent an electronic link to the UKCO annual report and accounts on March 15 by VA1 and VA2 sent them an (unabridged) hard copy of the annual report and accounts (ARA) on March 26. Neither the UKCO ARA nor the UKCO meeting notice (inclusive of proxy forms) were sent to IM5 by their custodial bank (GC4) because as GC4 explained: “Our agent, VA2 is responsible for distribution of annual reports and meeting notices”. Neither IM5 nor VA1 felt that UKCO need publish the ARA any earlier. But VA2 told us that: “We believe the timing of the release of the annual reports may generally be sufficient for registered shareholders. However, in the absence of an obligation for issuers to communicate with their beneficial shareholders, the receipt of these documents by these investors can be delayed due to shorter solicitation periods. Generally, for most non-North American markets, the release date of the annual report is too close to the meeting.”

#### The receipt of meeting notices (agenda, resolutions and proxy cards)

IM5 received an electronic link to the notice of meeting and proxy card from VA1 on March 15 but VA1 did not send them hard copies of these materials. But IM5 did receive hard copies of these materials from VA2 on March 26 (5 days after they were received by VA2 itself). Neither IM5 nor VA1 felt that UKCO need release these materials any earlier. VA2 commented, however, that: “In the UK, the Registrar requires the vote 48 hours prior to the meeting, but in the absence of a Record Date for voting, we have to impose a deadline around 5 days prior to the meeting in order to validate positions and process votes (physically) to the Registrar”. VA2 also observed that the short notice periods are particularly problematic for companies, like UKCO, who have sponsored ADR programmes. As they put it: “ADRs are generally treated as a North American security so the expectation is that the notifications for these meetings would follow the same time scale as for an actual North American issuer. However the notifications for these meetings are generally received much closer to the meeting date than for actual North American issuers and voting cut-off is earlier. ADR administration required by US agents further impinges on the time scales.”

**The return of proxy instructions to custodians/voting agents**

IM5 claim to have sent their vote instructions to both VA1 and VA2 by electronic link on April 15 (and to have received immediate electronic confirmation from VA2 that their vote instructions had been received). Unfortunately, neither VA1 nor VA2 were able to inform us as to the date on which they received these instructions.

**The execution of proxy instructions by custodians/voting agents**

VA1 were unable to inform us as to the date and manner in which these instructions were passed to the issuer's registrar. But VA2 told us that: "Normally, VA2 delivers the final vote instruction to the tabulator or sub-custodian. However, in the UK, we act as agent for some of our Nominee clients and send vote instructions direct to the registrar. For the UKCO meeting, the vote instructions were sent via electronic vote file and fax (dependant on the recipient) to the relevant sub-custodians on April 8th, and in our capacity as UK agent, VA2 submitted hard copy proxy cards to the Registrar on April 9th". In view of these deadlines, if IM5 did wait until April 15 before sending their vote instructions to VA2, it is probable these instructions never made it into the final proxy count.

### Case 6 (UK issuer)

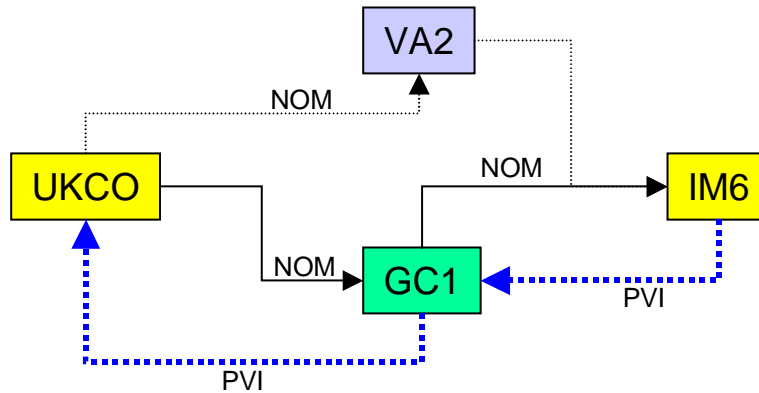

#### Holding pattern

IM6 held shares in UKCO through one global custodian (GC1).

#### The receipt of annual reports

In their questionnaire, IM6 indicated that they did not receive the UKCO annual report and accounts (ARA) from GC1 and made no comment as to whether UKCO should release the ARA any earlier.

#### The receipt of meeting notices (agenda, resolutions and proxy cards)

IM6 received an electronic link to an abridged summary of the UKCO meeting notice (showing only the resolutions and not the full text of the notice of meeting) from GC1 on March 18 and neither IM6 nor GC1 felt that UKCO need release these materials any earlier. IM6 also received a faxed summary of the meeting notice from VA2 on March 28 (although the reasons for this are not clear; in their questionnaire, IM6 did not indicate that VA2 had been appointed as their proxy voting agent in respect of UKCO).

#### The return of proxy instructions to custodians/voting agents

IM6 sent their vote instructions to GC1 by fax on April 7 but they did not receive any confirmation from GC1 that their instructions had been received and acted upon. GC1 explained their practice as follows: "Confirmation is based on exception processing – sub-custodians are contractually bound to deliver information to issuers/agents and only contact GC1 if the information was NOT delivered/accepted in a timely manner. Similarly GC1 will only 'negatively confirm'. We did not receive notice of failed votes for these (or any) votes in 2002."

#### The execution of proxy instructions by custodians/voting agents

GC1 couriered its proxy forms to the UKCO registrar on April 15 but did not obtain a receipt from the registrar acknowledging the delivery of the proxy forms.

### Case 7 (US issuer)

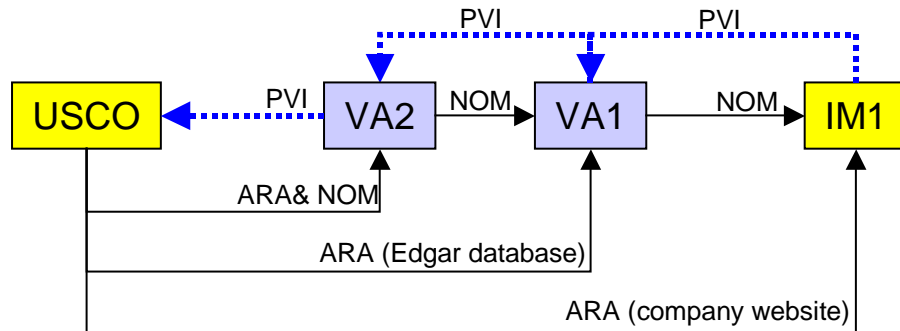

#### Holding pattern

IM1 held shares in USCO through 3 global custodians: GC1, GC7 and GC9. These custodians were not directly involved in the proxy voting process because, in each case, VA1 performed the role of proxy voting agent.

#### The receipt of annual reports

VA1 received a copy of the USCO annual report and accounts (ARA) by 'electronic feed' on March 8 (from the EDGAR database) and had no complaints about the timing of its release. VA1 did not relay the ARA to IM1 but the latter explained to us that: "We generally download the relevant figures / reports from the company's website. This is done with enough time to allow suitable analysis and for votes to be processed but no record is kept as to exact dates. In this instance we have no issues as to the timing and release/publishing of reports".

#### The receipt of meeting notices (agenda, resolutions and proxy cards)

VA2 received a full text hard copy of USCO's notice of meeting and proxy card on March 6. In turn, VA1 received (from VA2) the USCO meeting notice and agenda on March 8 (in data feed and hard copy, unabridged) and the proxy cards on March 18 (hard copy, unabridged). Unfortunately, IM1 were unable to confirm the dates on which it received these materials from VA1 (although it did note that it received an initial meeting notice from VA1 by electronic link on February 22). However, neither IM1 nor VA1 felt the need for USCO to release these materials any earlier.

#### The return of proxy instructions to custodians/voting agents

IM1 were unable to specify the date on which it sent its voting instructions to VA1 but it did indicate that the medium used was that of an 'electronic link'. Just over a month later (May 3) IM1 received confirmation from VA1 (via monthly email report) that VA1 had received and acted upon its vote instructions. These instructions were sent to VA2 for vote execution but unfortunately, VA1 did not specify the date and format of this transaction, nor did they specify whether VA2 had confirmed the receipt of the instructions sent to them.

#### The execution of proxy instructions by custodians/voting agents

With regard to the delivery of vote instructions, VA2 note that vote instructions were sent to the tabulator via electronic vote file and hard copy beginning March 27 and concluding on April 17, in line with market practice. In addition, VA2 monitors the vote file to ensure pick up by the tabulators

### Case 8 (US issuer)

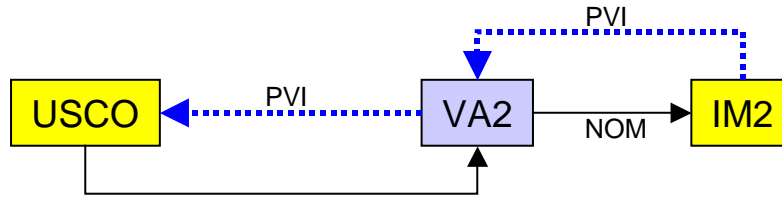

#### Holding pattern

IM2 held shares in USCO through one global custodian (GC1). This custodian were not directly involved in the voting process because the role of proxy voting agent was assigned to VA2.

#### The receipt of annual reports

IM2 did not receive the annual report and accounts (ARA) from their custodian (GC1) and did not feel the need for USCO to release the ARA “any earlier”.

#### The receipt of meeting notices (agenda, resolutions and proxy cards)

VA2 received a full text hard copy of USCO’s notice of meeting and proxy card on March 6. But IM2 claim not to have received these materials until ‘mid April’ when they received an email from VA2 containing a summarised notice (showing only the resolutions and not the full text).

#### The return of proxy instructions to custodians/voting agents

The delay in receiving the meeting notice appears, however, to have been of little consequence, as IM2 had lodged ‘standing instructions’ with VA2.

#### The execution of proxy instructions by custodians/voting agents

With regard to the delivery of vote instructions, VA2 note that vote instructions were sent to the tabulator via electronic vote file and hard copy beginning March 27 and concluding on April 17, in line with market practice. In addition, VA2 monitors the vote file to ensure pick up by the tabulators.

**Case 9 (US issuer)**

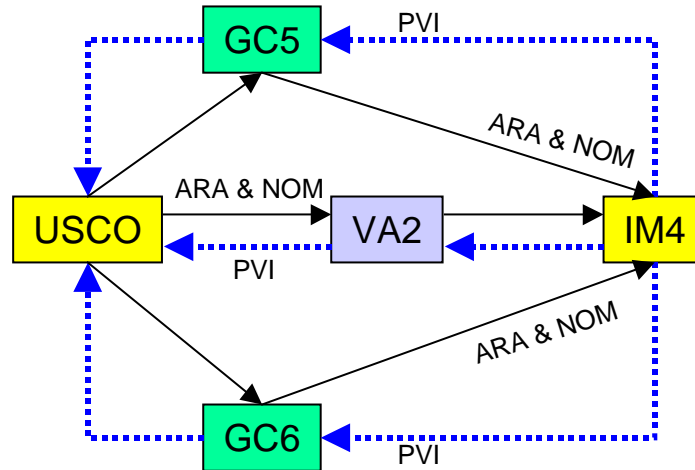

**Holding pattern**

IM4 held shares in USCO through eight global custodians. Six of these custodians were not directly involved in the proxy voting process (having contracted with VA2 to perform this role). But the remaining two custodians – GC5 and GC6 – were involved in the proxy voting process (as illustrated in the diagram).

**The receipt of annual reports**

VA2 received full text copies (in both hard form and electronic form) of the USCO annual report and accounts (ARA) on March 6. We do not know the dates on which the ARA was received by GC5 and GC6. IM4 obtained full text hard copies of the USCO annual report and accounts (ARA) from VA2 on March 12, from GC5 on March 15 and from GC6 on March 21. Neither IM4 nor VA2 felt the need for USCO to release the ARA any earlier. As observed by VA2: “The market-defined time scales and the regulation enfranchising all levels of shareholder dictates a suitable release date of the annual report and accounts”. With respect to GC5 and GC6, their views on this subject are not known, as they did not participate in the ICGN audit.

**The receipt of meeting notices (agenda, resolutions and proxy cards)**

IM4 received an electronic notice of the meeting from VA2 on March 7 but this contained only the agenda and ballot (i.e. not the full text of the meeting notice). From GC5 and GC6, IM4 received full text hard copies of the meeting notice at the same time as the annual report (i.e. March 15 and March 21 respectively). Once again, neither IM4 nor VA2 felt that the need for USCO to release the meeting notice (and proxy cards) any earlier.

**The return of proxy instructions to custodians/voting agents**

IM4 sent vote instructions by electronic link to VA2 on March 25 and received an immediate receipt confirmation. On the same day they also mailed their vote instructions to GC5 and GC6 (but received no confirmation of receipt).

**The execution of proxy instructions by custodians/voting agents**

With regard to the delivery of vote instructions, VA2 note that vote instructions were sent to the tabulator via electronic vote file and hard copy beginning March 27 and concluding on April 17, in line with market practice. In addition, VA2 monitors the vote file to ensure pick-up by the tabulators (absent the participation of GC5 and GC6 in the ICGN survey, we do not know the date on which their instructions were sent to the tabulator).

### Case 10 (US issuer)

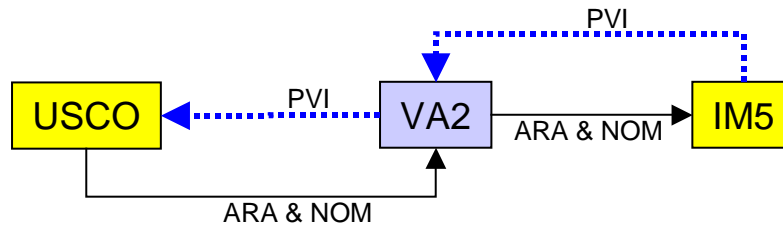

#### Holding pattern

IM5 held shares in USCO through one global custodian (GC4). This custodian was not directly involved in the voting process because the role of proxy voting agent was assigned to VA2.

#### The receipt of annual reports

VA2 received full text copies (in both hard form and electronic form) of the USCO annual report and accounts (ARA) on March 6. IM5 were sent a full-text hard copy of the USCO annual report and accounts on March 12 by VA2. Neither IM5 nor VA2 felt the need for USCO to release the ARA any earlier. As observed by VA2: "The market-defined time scales and the regulation enfranchising all levels of shareholder dictates a suitable release date of the annual report and accounts".

#### The receipt of meeting notices (agenda, resolutions and proxy cards)

IM5 received from VA2 a full-text hard copy of the USCO meeting notice, agenda and proxy card at the same time as the annual report (i.e. March 12).

#### The return of proxy instructions to custodians/voting agents

IM5 sent vote instructions by electronic link to VA2 on April 12 and received an immediate receipt confirmation.

#### The execution of proxy instructions by custodians/voting agents

With regard to the delivery of vote instructions, VA2 note that vote instructions were sent to the tabulator via electronic vote file and hard copy beginning March 27 and concluding on April 17, in line with market practice. In addition, VA2 monitors the vote file to ensure pick up by the tabulators.

### Case 11 (US issuer)

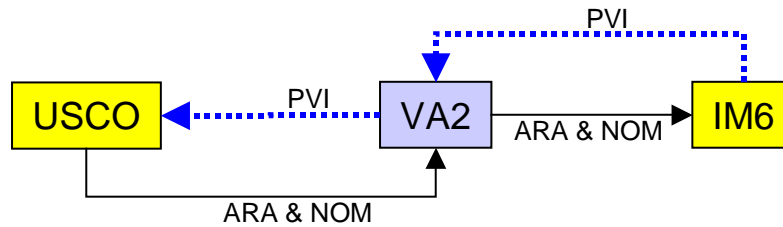

#### Holding pattern

IM6 held shares in USCO through one global custodian (GC11). This custodian was not directly involved in the voting process because the role of proxy voting agent was assigned to VA2.

#### The receipt of annual reports

VA2 received full text copies (in both hard form and electronic form) of the USCO annual report and accounts (ARA) on March 6. IM6 were sent a full text hard copy of the USCO annual report and accounts on March 13 by VA2. Neither IM6 nor VA2 felt the need for USCO to release the ARA any earlier. As observed by VA2: “The market-defined time scales and the regulation enfranchising all levels of shareholder dictates a suitable release date of the annual report and accounts”.

#### The receipt of meeting notices (agenda, resolutions and proxy cards)

IM6 received from VA2 a full text hard copy of the USCO meeting notice, agenda and proxy card at the same time as the annual report (i.e. March 13).

#### The return of proxy instructions to custodians/voting agents

IM6 sent vote instructions by electronic link to VA2 on April 4 and received an immediate receipt confirmation.

#### The execution of proxy instructions by custodians/voting agents

With regard to the delivery of vote instructions, VA2 note that vote instructions were sent to the tabulator via electronic vote file and hard copy beginning March 27 and concluding on April 17, in line with market practice. In addition, VA2 monitors the vote file to ensure pick up by the tabulators.

## Case 12 (Italian issuer)

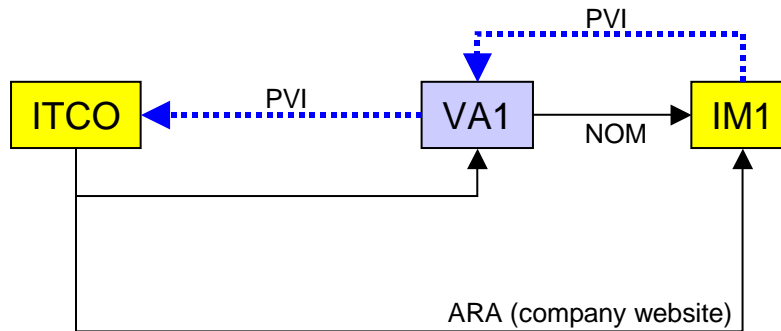

### Holding pattern

IM1 held shares in ITCO through 4 global custodians: GC1, GC7, GC9 and GC10. These custodians were not directly involved in the proxy voting process because, in each case, VA1 performed the role of proxy voting agent.

### The receipt of annual reports

VA1 did not receive the ITCO annual report and accounts (ARA) until May 10 (four days after the annual general meeting). The ARA which they received (in hard copy) was not translated into English and VA1 felt that “the annual report and accounts should accompany the notice of meeting so the analysts can look at the directors’ and financial information”. However, despite the tardy release of the annual report (and the fact that it was not forwarded on to them), IM1 explained that: “We generally download the relevant figures / reports from the company’s website. This is done with enough time to allow suitable analysis and for votes to be processed but no record is kept as to exact dates. In this instance we have no issues as to the timing and release/publishing of reports”.

### The receipt of meeting notices (agenda, resolutions and proxy cards)

VA1 suggested that they obtained - from the ITCO website - a summarised Italian version of the ITCO meeting notice on April 1. But, according to IM1, it was another 29 days (April 30) before they were supplied by VA1 with a copy of the meeting notice (i.e. one just one week before the meeting itself). However, when this (electronic) copy did arrive, it had the benefits of a full text English translation and IM1 registered no complaints about the late receipt of this notice.

### The return of proxy instructions to custodians/voting agents

IM1 sent their voting instructions in respect of ITCO to VA1 (via electronic link) on April 30. Ten weeks later, (July 10), IM1 received confirmation from VA1 (via quarterly email report) that VA1 had received and acted upon their vote instructions.

### The execution of proxy instructions by custodians/voting agents

VA1 did not answer the following questions: To whom were these instructions were passed? On what date? In what format? Did you obtain confirmation from the Issuer’s registrar/transfer agent that they had received the proxy cards delivered to them?

### Case 13 (Italian issuer)

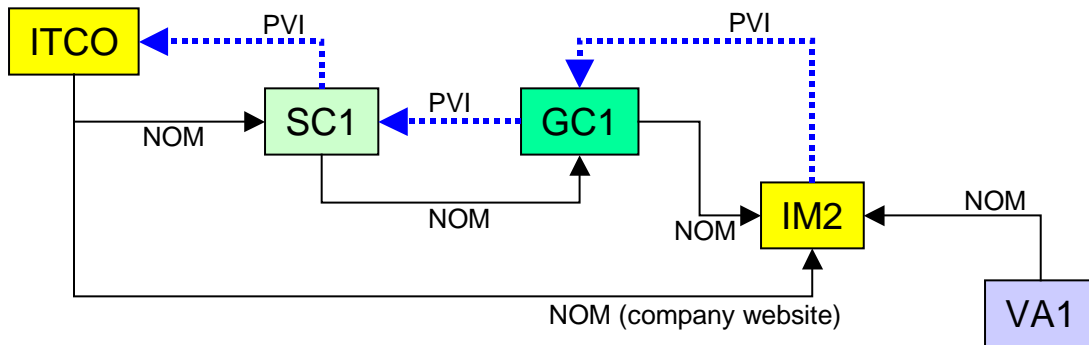

#### Holding pattern

IM2 held shares in ITCO through one global custodian (GC1).

#### The receipt of annual reports

IM2 did not receive the annual report and accounts (ARA) from their custodian (GC1) and did not feel the need for ITCO to release the ARA “any earlier”. On this subject, GC1 observed that it “does not receive financial statements for onward distribution” adding that: “In most cases, no information is collected and distributed because it is only available in hard copy, making collection and distribution too expensive and time consuming. If electronic information was readily available (or preferably, if a Web URL directing interested parties to a company hosted site containing such information was available), GC1 believe market practice would rapidly evolve to include such information”.

#### The receipt of meeting notices (agenda, resolutions and proxy cards)

GC1’s sub-custodian (SC1) obtained ITCO’s meeting notice on April 1 from the Gazette Ufficiale (hard copy stock exchange publication) and relayed a summarised (and translated) notice to GC1 two days later (on April 3) via SWIFT and fax/email. In turn, IM2 received this summarised notice via GC1’s proprietary electronic link (although IM2 did not indicate the date on which this was received). Rather surprisingly (given that the ITCO meeting did not take place until May 6), both GC1 and IM2 felt that the notice period was ‘insufficient’. IM2 also obtained a summarised copy (showing only the resolutions) of the ITCO meeting notice from the VA1 ProxyMaster website on April 16 and from ITCO’s own website (date unspecified).

IM2 also note that: “Due to the inflexibility of GC1’s system, this information is only available for one day. Once the standing instructions are activated by GC1, we can no longer download this information.” IM2 also note that the proprietary link used by GC1 only shows the resolutions and not the full text of the notice of meeting. This is something that GC1 themselves acknowledged when they told us that: “Summarised agendas are clear area for improvement. Currently the distribution methods that exist between our sub-custodians as well as our own electronic distribution capabilities to clients do not cater for transmittal of complete un-abbreviated agenda resolutions.”

#### The return of proxy instructions to custodians/voting agents

IM2 sent all their voting instructions in respect of ITCO to GC1 (via electronic link) on April 17 but they did not receive any confirmation from GC1 that their instructions had been received and acted upon. GC1 explained their practice as follows: “Confirmation is based on exception processing – sub-custodians are contractually bound to deliver information to issuers/agents and only contact GC1 if the information was NOT delivered/accepted in a timely manner. Similarly GC1 will only ‘negatively confirm’. We did not receive notice of failed votes for these (or any) votes in 2002.”

**The execution of proxy instructions by custodians/voting agents**

GC1 then sent these vote instructions to its sub-custodian (SC1) by Telex (changing to Swift in 2003) on April 18. Although they give no precise date in respect of ITCO, GC1 claim that, in general, its sub-custodians deliver the vote instructions to the company registrar/transfer agent within 24 hours of receipt of votes from GC1.

**Case 14 (Italian issuer)**

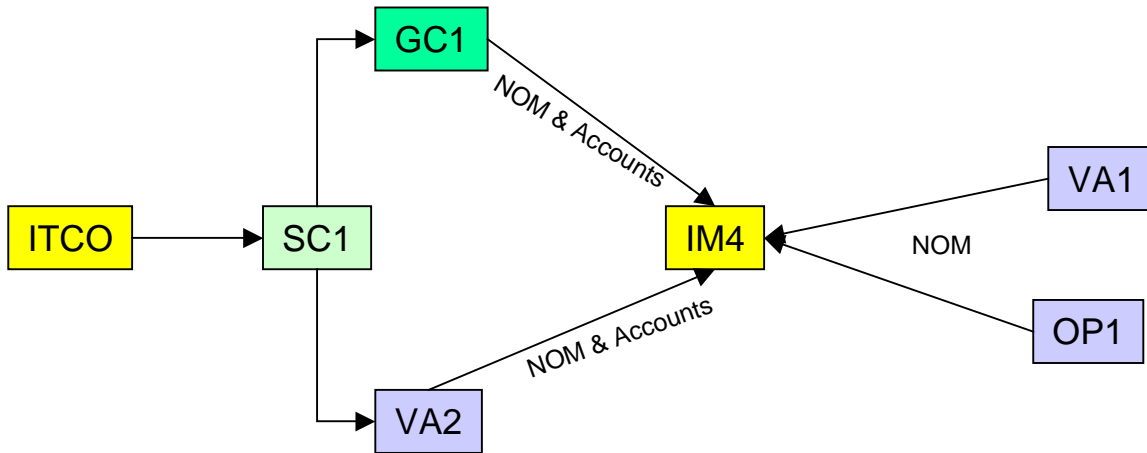

**Holding pattern**

IM4 held shares in ITCO through two global custodians: GC1 and GC4. For the shares held through GC4, VA2 performed the role of proxy agent.

**The receipt of annual reports**

IM4 did not receive ITCO’s annual report from any custodial/voting agent but they did receive an English language version of the accounts (by electronic link) from GC1 on April 8 and from VA2 on April 9 (by PDF email attachment, likewise translated into English). Asked to comment on the timing of the annual report, GC1 replied: “In most cases, no information is collected and distributed because it is only available in hard copy, making collection and distribution too expensive and time consuming. If electronic information was readily available (or preferably, if a Web URL directing interested parties to a company hosted site containing such information was available), GC1 believe market practice would rapidly evolve to include such information...We believe the timing of report information would in most cases be acceptable, if the method of delivery could be changed.” On the same subject, VA2 declared its belief that: “We believe the timing of the release of the annual report and accounts may generally be sufficient for registered shareholders. However, in the absence of obligation for issuers to communicate with their beneficial shareholders, the receipt of these documents by these investors can be delayed due to shorter solicitation periods. Generally, for most non-North American markets, the release date of the annual report is too close to the meeting.”

**The receipt of meeting notices (agenda, resolutions and proxy cards)**

GC1’s sub-custodian (SC1) obtained the full text of the ITCO meeting notice on April 1 from the Gazette Ufficial (hard copy stock exchange publication) and relayed a summarised (and translated) meeting notice and agenda to GC1 two days later (on April 3) via SWIFT and fax/email and via SWIFT to VA2. IM4, in turn, received the summarised meeting notice from VA2 on April 5 (via electronic link) and from GC1 on April 8 (via GC1’s proprietary electronic link). IM4 also received the ITCO meeting notice from two other sources: VA1 and OP1. Rather surprisingly (given that the ITCO meeting did not take place until May 6), GC1 felt that the notice period was ‘insufficient’. On the same subject, VA2 observed that: “In Italy, we implement a deadline 8 days prior to the meeting in order to accommodate Market and Agents’ own deadlines” as a consequence of which “there is often a limited time between the beneficial shareholder receiving the notice and needing to instruct their vote”. But IM4 considered that “the meeting notice publication date was fine but the earlier the better”.

**The return of proxy instructions to custodians/voting agents**

IM4 did not return any vote instructions “because of shareblocking” (they did not elaborate further on this subject).

## Case 15 (Italian issuer)

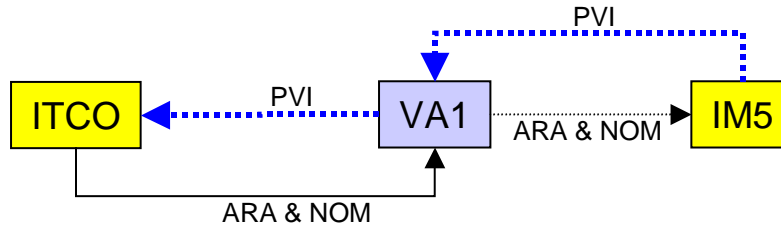

### Holding pattern

IM5 held shares in ITCO through one global custodian (GC4). This custodian was not directly involved in the voting process because the role of proxy voting agent was assigned to VA1.

### The receipt of annual reports

VA1 did not receive the ITCO annual report and accounts (ARA) until May 10 (four days after the annual general meeting). The ARA which they received (in hard copy) was not translated into English and VA1 felt that “the annual report and accounts should accompany the notice of meeting so the analysts can look at the directors’ and financial information”. IM5 indicated this material was relayed to them in electronic form by VA1 but they did not state the date on which this occurred (nor did they express an opinion on whether these materials should be released any earlier).

### The receipt of meeting notices (agenda, resolutions and proxy cards)

VA1 obtained - from the ITCO website - a summarised Italian version of the ITCO meeting notice on 1 April. IM5 indicated this material was relayed to them in electronic form by VA1 but they did not state the date on which this occurred (nor whether this material should be released any earlier).

### The return of proxy instructions to custodians/voting agents

IM5 claim they sent proxy vote instructions - in respect of the ITCO meeting – to VA1 by electronic link but they do not indicate the date on which these instructions were sent.

### The execution of proxy instructions by custodians/voting agents

VA1 did not answer the following questions: To whom were these instructions were passed? On what date? In what format? Did you obtain confirmation from the Issuer’s registrar/transfer agent that they had received the proxy cards delivered to them?

### Case 16 (Italian issuer)

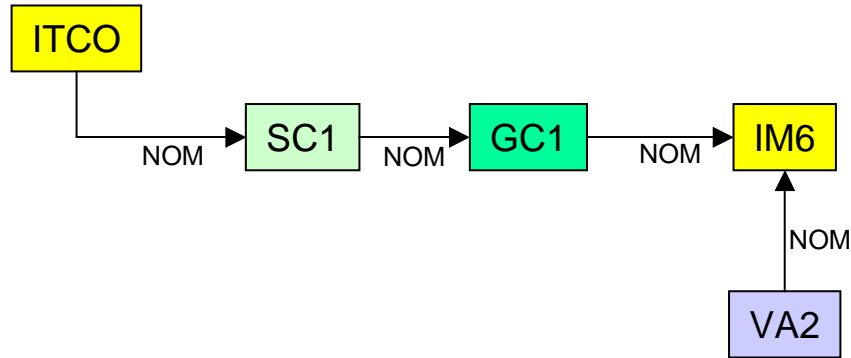

#### Holding pattern

IM6 held shares in ITCO through one global custodian (GC1).

#### The receipt of annual reports

IM6 did not receive the annual report and accounts (ARA) from their custodian (GC1) and did not feel the need for ITCO to release the ARA “any earlier”. On this subject, GC1 observed that it “does not receive financial statements for onward distribution” adding that: “In most cases, no information is collected and distributed because it is only available in hard copy, making collection and distribution too expensive and time consuming. If electronic information was readily available (or preferably, if a Web URL directing interested parties to a company hosted site containing such information was available), GC1 believe market practice would rapidly evolve to include such information”.

#### The receipt of meeting notices (agenda, resolutions and proxy cards)

GC1’s sub-custodian (SC1) obtained ITCO’s meeting notice on April 1 from the Gazette Ufficiale (hard copy stock exchange publication) and relayed a summarised (and translated) notice two days later (on April 3) via SWIFT and fax/email to GC1. IM6, in turn, received the summarised meeting notice from GC1 on April 5 (via electronic link). IM6 also received a faxed copy of the ITCO meeting notice from VA2 on April 9. Rather surprisingly (given that the ITCO meeting did not take place until May 6), GC1 felt that the notice period was ‘insufficient’. But IM6 did not feel the company need publish the meeting notice any earlier.

#### The return of proxy instructions to custodians/voting agents

IM6 did not return any vote instructions “because of lending activity” (they did not elaborate further on this subject).

### Case 17 (German issuer)

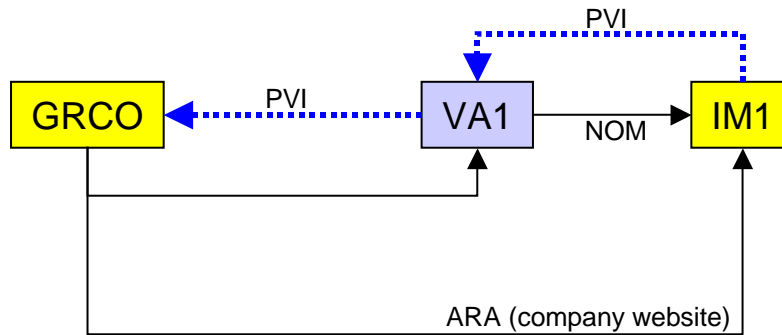

#### Holding pattern

IM1 held shares in DECO through 2 global custodians: GC8 and GC4. These custodians were not directly involved in the proxy voting process because, in each case, VA1 performed the role of proxy voting agent.

#### The receipt of annual reports

VA1 obtained the DECO annual report and accounts (ARA) from the company's website on May 3 and had no complaints about the timing of its release. VA1 did not relay the ARA to IM1 but the latter explained to us that: "We generally download the relevant figures / reports from the company's website. This is done with enough time to allow suitable analysis and for votes to be processed but no record is kept as to exact dates. In this instance we have no issues as to the timing and release/publishing of reports".

#### The receipt of meeting notices (agenda, resolutions and proxy cards)

VA1 received full a German language full text copy of the DECO meeting notice and agenda on May 3 (in hard copy and fax) and an English language version of the proxy cards on May 28 (by data feed and fax). In turn, IM1 obtained all these materials (in full text, English language versions) from VA1 by electronic link on May 28. Neither IM1 nor VA1 felt the need for DECO to release these materials any earlier.

#### The return of proxy instructions to custodians/voting agents

IM1 sent their voting instructions in respect of DECO to VA1 (via electronic link) on May 30. Six weeks later, (July 10), IM1 received confirmation from VA1 (via monthly email report) that VA1 had received and acted upon their vote instructions.

#### The execution of proxy instructions by custodians/voting agents

VA1 did not answer the following questions: To whom were these instructions were passed? On what date? In what format? Did you obtain confirmation from the Issuer's registrar/transfer agent that they had received the proxy cards delivered to them?

### Case 18 (German issuer)

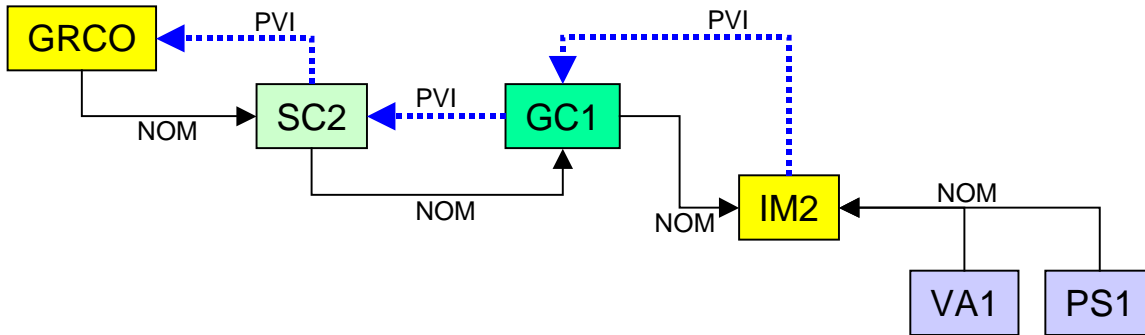

#### Holding pattern

IM2 held shares in ITCO through one global custodian (GC1).

#### The receipt of annual reports

IM2 did not receive the annual report and accounts (ARA) from their custodian (GC1) and did not feel the need for DECO to release the ARA “any earlier”. On this subject, GC1 observed that it “does not receive financial statements for onward distribution” adding that: “In most cases, no information is collected and distributed because it is only available in hard copy, making collection and distribution too expensive and time consuming. If electronic information was readily available (or preferably, if a Web URL directing interested parties to a company hosted site containing such information was available), GC1 believe market practice would rapidly evolve to include such information”.

#### The receipt of meeting notices (agenda, resolutions and proxy cards)

GC1’s sub-custodian (SC2) obtained the full text of the DECO meeting notice on May 2 from the Bundesanzeiger (Federal Daily Gazette) and relayed a summarised (and translated) meeting notice and agenda to GC1 four days later (on May 6) via SWIFT and fax/email. In turn, IM2 received this summarised notice via GC1’s proprietary electronic link (although IM2 did not indicate the date on which this was received). Neither IM2 nor GC1 felt the need for DECO to release these materials any earlier. IM2 also obtained a full text hard copy of the meeting notice from PS1 Services on May 21 and a summarised copy (showing only the resolutions) from the VA1 ProxyMaster website on May 25.

IM2 also note that: “Due to the inflexibility of GC1’s system, this information is only available for one day. Once the standing instructions are activated by GC1, we can no longer download this information.” IM2 also note that the proprietary link used by GC1 only shows the resolutions and not the full text of the notice of meeting. This is something that GC1 themselves acknowledged when they told us that: “Summarised agendas are clear area for improvement. Currently the distribution methods that exist between our sub-custodians as well as our own electronic distribution capabilities to clients do not cater for transmittal of complete un-abbreviated agenda resolutions.”

#### The return of proxy instructions to custodians/voting agents

IM2 sent all their voting instructions in respect of DECO to GC1 (via electronic link) on May 30 but they did not receive any confirmation from GC1 that their instructions had been received and acted upon. GC1 explained their practice as follows: “Confirmation is based on exception processing – sub-custodians are contractually bound to deliver information to issuers/agents and only contact GC1 if the information was NOT delivered/accepted in a timely manner. Similarly GC1 will only ‘negatively confirm’. We did not receive notice of failed votes for these (or any) votes in 2002.”

**The execution of proxy instructions by custodians/voting agents**

GC1 then sent these vote instructions to its sub-custodian (SC2) by Telex (changing to Swift in 2003) on May 31. Although they give no precise date in respect of DECO, GC1 claim that, in general, its sub-custodians deliver the vote instructions to the company registrar/transfer agent within 24 hours of receipt of votes from GC1.

### Case 19 (German issuer)

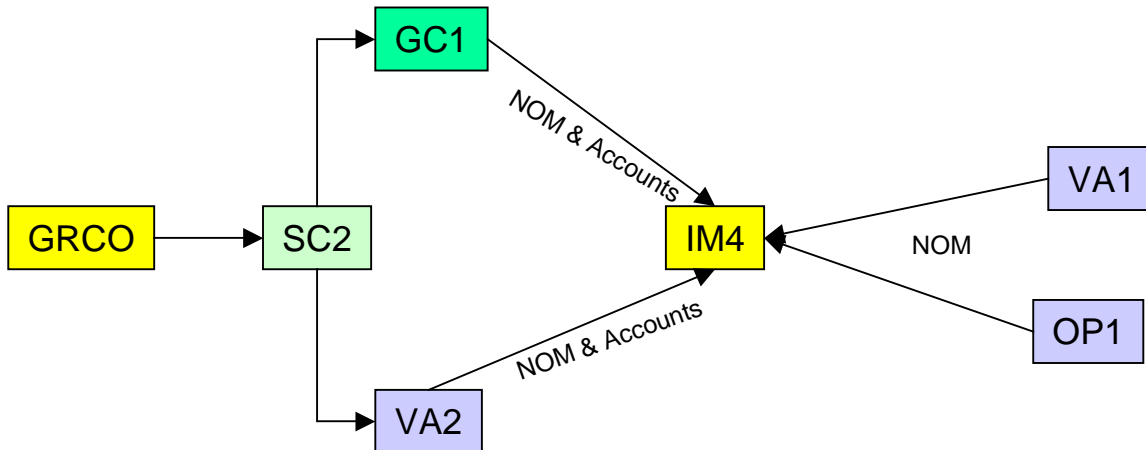

#### Holding pattern

IM4 held shares in DECO through three global custodians: GC1, GC4 and GC3. For the shares held through GC4 and GC3, VA2 performed the role of proxy agent.

#### The receipt of annual reports

IM4 did not receive the DECO annual report from any custodial/voting agent but they did receive an English language version of the accounts (by electronic link) from GC1 on May 7 and from VA2 on May 17 (by PDF email attachment, likewise translated into English). Asked to comment on the timing of the annual report, GC1 replied: "In most cases, no information is collected and distributed because it is only available in hard copy, making collection and distribution too expensive and time consuming. If electronic information was readily available (or preferably, if a Web URL directing interested parties to a company hosted site containing such information was available), GC1 believe market practice would rapidly evolve to include such information...We believe the timing of report information would in most cases be acceptable, if the method of delivery could be changed." On the same subject, VA2 declared its belief that: "We believe the timing of the release of the annual report and accounts may generally be sufficient for registered shareholders. However, in the absence of obligation for issuers to communicate with their beneficial shareholders, the receipt of these documents by these investors can be delayed due to shorter solicitation periods. Generally, for most non-North American markets, the release date of the annual report is too close to the meeting."

#### The receipt of meeting notices (agenda, resolutions and proxy cards)

GC1's sub-custodian (SC2) obtained the full text of the DECO meeting notice on May 2 from the Bundesanzeiger (Federal Daily Gazette) and relayed a summarised (and translated) meeting notice and agenda to GC1 four days later (on May 6) via SWIFT and fax/email and via SWIFT to VA2. IM4, in turn, received the summarised meeting notice from both GC1 and VA2 on the following day (May 7) via electronic link. IM4 also received the DECO meeting notice from two other sources: VA1 and OP1. Although GC1 had no complaints about the timing of the meeting notice, VA2 observed that: "In Germany, we implement a deadline 10 days prior to the meeting in order to accommodate Market and Agents' own deadlines" as a consequence of which "there is often a limited time between the beneficial shareholder receiving the notice and needing to instruct their vote". But IM4 considered that "the meeting notice publication date was fine".

#### The return of proxy instructions to custodians/voting agents

IM4 did not return any vote instructions "because of shareblocking" (they did not elaborate further on this subject).

## Case 20 (German issuer)

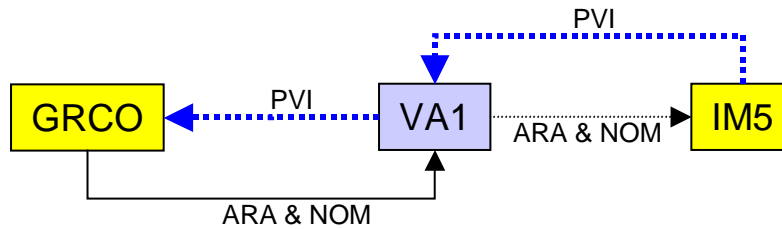

### Holding pattern

IM5 held shares in DECO through one global custodian (GC4). This custodian was not directly involved in the voting process because the role of proxy voting agent was assigned to VA1.

### The receipt of annual reports

VA1 obtained the DECO annual report and accounts (ARA) from the company's website on May 3. A link to this report (which was not translated into English) was sent by VA1 to IM5 on May 30 and (despite this time lag) neither IM5 nor VA1 had any complaints about the timing of the ARA.

### The receipt of meeting notices (agenda, resolutions and proxy cards)

VA1 received a German language full text copy of the DECO meeting notice and agenda on May 3 (in hard copy and fax) and an English language version of the proxy cards on May 28 (by data feed and fax). In turn, IM5 obtained all these materials (in full text, English language versions) from VA1 by electronic link on May 30. Neither IM5 nor VA1 felt the need for DECO to release these materials any earlier.

### The return of proxy instructions to custodians/voting agents

IM5 sent their voting instructions in respect of DECO to VA1 (via electronic link) on May 30 and claim to have received immediate electronic confirmation from VA1 that their vote instructions had been received.

### The execution of proxy instructions by custodians/voting agents

VA1 did not answer the following questions: To whom were these instructions were passed? On what date? In what format? Did you obtain confirmation from the Issuer's registrar/transfer agent that they had received the proxy cards delivered to them?

### Case 21 (German issuer)

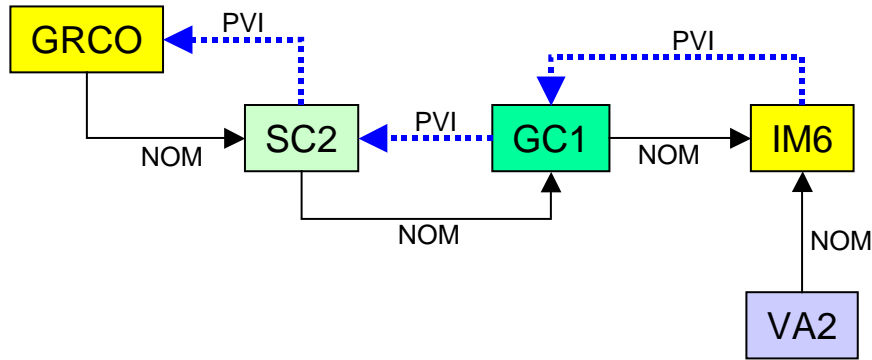

#### Holding pattern

IM6 held shares in DECO through one global custodian (GC1).

#### The receipt of annual reports

IM6 did not receive the annual report and accounts (ARA) from their custodian (GC1) and did not feel the need for DECO to release the ARA “any earlier”. On this subject, GC1 observed that it “does not receive financial statements for onward distribution” adding that: “In most cases, no information is collected and distributed because it is only available in hard copy, making collection and distribution too expensive and time consuming. If electronic information was readily available (or preferably, if a Web URL directing interested parties to a company hosted site containing such information was available), GC1 believe market practice would rapidly evolve to include such information”.

#### The receipt of meeting notices (agenda, resolutions and proxy cards)

GC1’s sub-custodian (SC2) obtained the full text of the DECO meeting notice on May 2 from the Bundesanzeiger (Federal Daily Gazette) and relayed a summarised (and translated) meeting notice and agenda to GC1 four days later (on May 6) via SWIFT and fax/email. IM6, in turn, received the summarised meeting notice from GC1 on May 6 (via electronic link). IM6 also received a faxed copy of the DECO meeting notice from VA2 on May 18. Neither IM6 nor GC1 felt the company need publish these materials any earlier.

#### The return of proxy instructions to custodians/voting agents

IM6 faxed all their voting instructions in respect of DECO to GC1 on May 30 but they did not receive any confirmation from GC1 that their instructions had been received and acted upon. GC1 explained their practice as follows: “Confirmation is based on exception processing – sub-custodians are contractually bound to deliver information to issuers/agents and only contact GC1 if the information was NOT delivered/accepted in a timely manner. Similarly GC1 will only ‘negatively confirm’. We did not receive notice of failed votes for these (or any) votes in 2002.”

#### The execution of proxy instructions by custodians/voting agents

GC1 then sent these vote instructions to its sub-custodian (SC2) by Tested Telex (changing to Swift in 2003) on May 31. Although they give no precise date in respect of ITCO, GC1 claim that, in general, its sub-custodians deliver the vote instructions to the company registrar/transfer agent within 24 hours of receipt of votes from GC1.

## Case 22 (Japanese issuer)

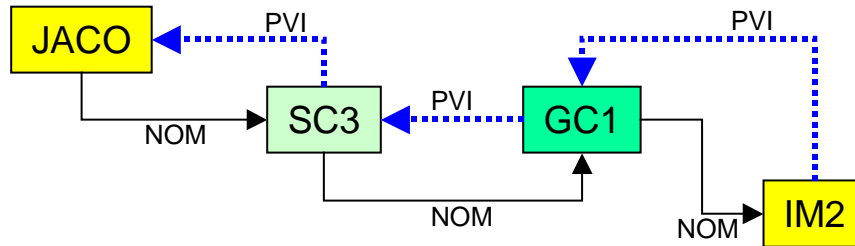

### Holding pattern

IM2 held shares in JACO through one global custodian (GC1).

### The receipt of annual reports

IM2 did not receive the annual report and accounts (ARA) from their custodian (GC1) and did not feel the need for JACO to release the ARA “any earlier”. On this subject, GC1 observed that it “does not receive financial statements for onward distribution” adding that: “In most cases, no information is collected and distributed because it is only available in hard copy, making collection and distribution too expensive and time consuming. If electronic information was readily available (or preferably, if a Web URL directing interested parties to a company hosted site containing such information was available), GC1 believe market practice would rapidly evolve to include such information”.

### The receipt of meeting notices (agenda, resolutions and proxy cards)

GC1’s sub-custodian (SC3) obtained the full text of the JACO meeting notice by hard copy mail on May 29 and relayed a summarised (and translated) meeting notice and agenda to GC1 on May 30 via SWIFT and fax/email. In turn, IM2 received this summarised notice via GC1’s proprietary electronic link (although IM2 did not indicate the date on which this was received). IM2 also note that: “Due to the inflexibility of GC1’s system, this information is only available for one day. Once the standing instructions are activated by GC1, we can no longer download this information.” IM2 also note that the proprietary link used by GC1 only shows the resolutions and not the full text of the notice of meeting. This is something that GC1 themselves acknowledged when they told us that: “Summarised agendas are clear area for improvement. Currently the distribution methods that exist between our sub-custodians as well as our own electronic distribution capabilities to clients do not cater for transmittal of complete un-abbreviated agenda resolutions.” Asked whether JACO should publish the notice of meeting any earlier, IM2 replied: “Almost certainly due to the schedule of AGMs in Japan”. On the same subject, our respondent at GC1 confined himself to the caustic (if somewhat gnostic) observation that “I believe anyone outside Japan thinks the Japanese system is absurd”.

### The return of proxy instructions to custodians/voting agents

In light of the complaints about the timing of Japanese meeting notices, one can understand IM2’ decision to lodge standing instructions with GC1 in respect of the JACO AGM. It should be noted, however, that IM2 did not receive any confirmation from GC1 that their standing instructions had been received and acted upon. GC1 explained their practice as follows: “Confirmation is based on exception processing – sub-custodians are contractually bound to deliver information to issuers/agents and only contact GC1 if the information was NOT delivered/accepted in a timely manner. Similarly GC1 will only ‘negatively confirm’. We did not receive notice of failed votes for these (or any) votes in 2002.”

### The execution of proxy instructions by custodians/voting agents

GC1 sent the vote instructions to its sub-custodian (SC3) by Tested Telex (changing to Swift in 2003) on June 20. Although they give no precise date in respect of JACO, GC1 claim that, in general, its sub-custodians deliver the vote instructions to the company registrar/transfer agent within 24 hours of receipt of votes from GC1.

### Case 23 (Japanese issuer)

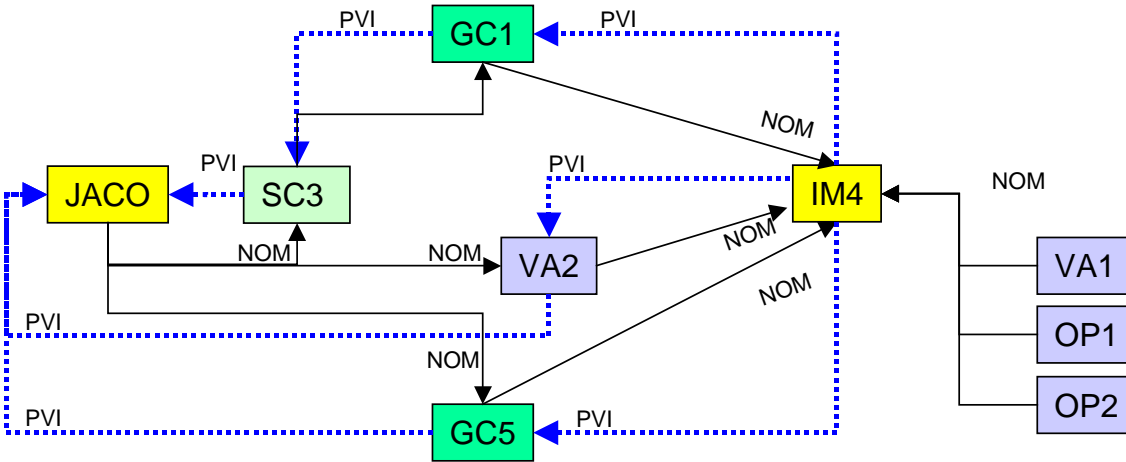

#### Holding pattern

IM4 held shares in JACO through four global custodians: GC1, GC4, GC5 and GC3. For the shares held through GC4 and GC3, VA2 performed the role of proxy voting agent.

#### The receipt of annual reports

IM4 did not receive the JACO annual report from any custodial/voting agent but they did receive (English language versions of) the accounts by fax from GC5 on May 30, by electronic link from GC1 on June 3, and by PDF email attachment from VA2 on June 4. Asked to comment on the timing of the annual report, GC1 replied: “In most cases, no information is collected and distributed because it is only available in hard copy, making collection and distribution too expensive and time consuming. If electronic information was readily available (or preferably, if a Web URL directing interested parties to a company hosted site containing such information was available), GC1 believe market practice would rapidly evolve to include such information...We believe the timing of report information would in most cases be acceptable, if the method of delivery could be changed.” On the same subject, VA2 declared its belief that: “The timing of the release of the annual report and accounts may generally be sufficient for registered shareholders. However, in the absence of obligation for issuers to communicate with their beneficial shareholders, the receipt of these documents by these investors can be delayed due to shorter solicitation periods. Generally, for most non-North American markets, the release date of the annual report is too close to the meeting.” With respect to GC5, their views on this subject are not known as they did not participate in the ICGN audit.

#### The receipt of meeting notices (agenda, resolutions and proxy cards)

GC1’s sub-custodian (SC3) obtained a full text, English language version of the JACO meeting notice by hard copy on May 29 and relayed it to GC1 on Thursday, May 30, via SWIFT and fax/email. GC1 claim they made this notice available – via its proprietary electronic link - to IM4 on the same day (i.e. May 30) but IM4 claim they did not receive this notice until the following Monday (i.e. June 3). Likewise, although VA2 received the complete meeting agenda via electronic file transfer and email on May 29, it was not emailed to IM4 until the following Monday (and not received by IM4 until June 4). With respect to GC5, we do not know on what date they received the JACO meeting notice (as they did not participate in the ICGN audit) but IM4 informed us that they received, from GC5, an English language faxed copy of the meeting notice on May 30. IM4 also received the JACO meeting notice from three other sources: VA1, OP1 and OP2.

Asked whether JACO should publish the notice of meeting any earlier, IM4 replied “yes, because we receive the actual proxy very close to the vote deadline date”; whilst our respondent at GC1 confined himself to the caustic (if somewhat gnostic) observation that “I believe anyone outside Japan thinks the

Japanese system is absurd". On the same subject, VA2 observed that: "In Japan, we implement a deadline of 8 days prior to the meeting in order to accommodate Market and Agents' own deadlines" as a consequence of which "there is often a limited time between the beneficial shareholder receiving the notice and needing to instruct their vote".

**The return of proxy instructions to custodians/voting agents**

In light of the complaints about the timing of Japanese meeting notices, one can understand IM4's decision to lodge standing proxy instructions with their custodians and voting agents in respect of the JACO AGM. It should be noted, however, that IM4 did not receive any confirmation - from GC1, VA2 or GC5 - that their standing instructions had been received and acted upon. GC1 explained their practice as follows: "Confirmation is based on exception processing – sub-custodians are contractually bound to deliver information to issuers/agents and only contact GC1 if the information was NOT delivered/accepted in a timely manner. Similarly GC1 will only 'negatively confirm'. We did not receive notice of failed votes for these (or any) votes in 2002." On the same subject VA2 told us that clients voting on non-North American securities can opt to receive a Daily Activity Report (presumably IM4 did not opt for this facility).

**The execution of proxy instructions by custodians/voting agents**

VA2 delivered the final vote instruction to its "appointed Agent in Japan on June 4, who then filled out the proxy card(s) and delivered them to the issuer" (date unspecified). Somewhat later (on June 20), GC1 sent its vote instructions to its sub-custodian (SC3) by Telex (changing to Swift in 2003). Although they give no precise date in respect of JACO, GC1 claim that, in general, its sub-custodians deliver the vote instructions to the company registrar/transfer agent within 24 hours of receipt of votes from GC1.

### Case 24 (Japanese issuer)

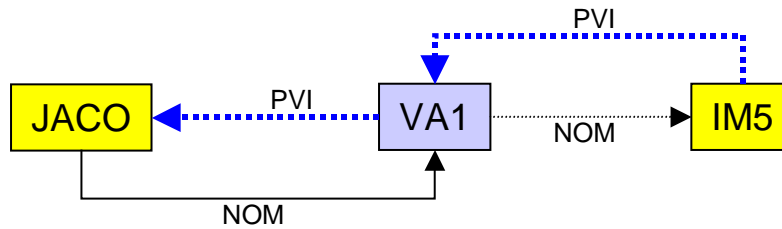

#### Holding pattern

IM5 held shares in JACO through one global custodian (GC4). This custodian was not directly involved in the voting process because the role of proxy voting agent was assigned to VA1.

#### The receipt of annual reports

VA1 did not receive a copy of the JACO annual report and accounts (which, was not sent to the client's custodial bank until June 27, i.e. a day after the annual general meeting) and were unable, therefore, to relay it to IM5. Although IM5 themselves made no comment on the timing of the annual report, VA1 were clearly unhappy with the timing and felt that the annual report should be sent with the notice of the meeting.

#### The receipt of meeting notices (agenda, resolutions and proxy cards)

VA1 received a Japanese language full text copy of the JACO meeting notice and agenda on May 29 (in hard copy and fax) and an English language version of the proxy cards on June 4 (by data feed and fax). In turn, IM5 obtained all these materials (in full text, English language versions) from VA1 by electronic link on June 4. Neither IM5 nor VA1 felt the need for JACO to release these materials any earlier.

#### The return of proxy instructions to custodians/voting agents

IM5 sent their voting instructions in respect of JACO to VA1 (via electronic link) on June 5 and received immediate electronic confirmation from VA1 that their vote instructions had been received.

#### The execution of proxy instructions by custodians/voting agents

VA1 did not answer the following questions: To whom were these instructions were passed? On what date? In what format? Did you obtain confirmation from the Issuer's registrar/transfer agent that they had received the proxy cards delivered to them?

### Case 25 (Japanese issuer)

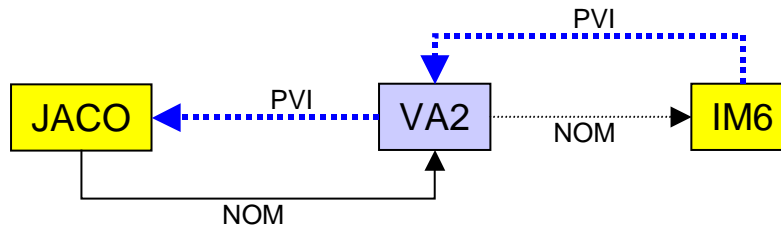

#### Holding pattern

IM6 held shares in JACO through one global custodian (GC11) who in turn was represented by its sub-custodian (SC4). These custodians were not directly involved in the voting process because the role of proxy voting agent was assigned to VA2.

#### The receipt of annual reports

VA2 did not receive a copy of the JACO annual report and accounts (which, was not sent to the client's custodial bank until June 27, i.e. a day after the annual general meeting) and were unable, therefore, to relay it to IM6. Although IM6 themselves made no comment on the timing of the annual report, VA2 observed that: "The timing of the release of the annual report and accounts may generally be sufficient for registered shareholders. However, in the absence of an obligation for issuers to communicate with their beneficial shareholders, the receipt of these documents by these investors can be delayed due to shorter solicitation periods. Generally, for most non-North American markets, the release date of the annual report is too close to the meeting."

#### The receipt of meeting notices (agenda, resolutions and proxy cards)

VA2 received the complete JACO meeting agenda via electronic file transfer and email on May 29 but it was not faxed (in a summarised, English language version) to IM6 until the following Monday (June 3) and not actually received by IM6 until June 4. Asked whether JACO should publish the notice of meeting any earlier, VA2 observed that: "In Japan, we implement a deadline of 8 days prior to the meeting in order to accommodate Market and Agents' own deadlines" as a consequence of which "there is often a limited time between the beneficial shareholder receiving the notice and needing to instruct their vote". In answer to the same question, IM6 replied: "Yes, because Japanese meetings are generally concentrated between a few days. An earlier meeting notice would be helpful in getting all Japanese proxies voted".

#### The return of proxy instructions to custodians/voting agents

In light of the complaints about the timing of Japanese meeting notices, one can understand IM6's decision to lodge standing proxy instructions with their voting in respect of the JACO AGM. It should be noted, however, that IM6 did not receive any confirmation from VA2 that their standing instructions had been received and acted upon. But VA2 told us that clients voting on non-North American securities can opt to receive a Daily Activity Report (presumably IM6 did not opt for this facility).

#### The execution of proxy instructions by custodians/voting agents

VA2 delivered the final vote instruction to its "appointed Agent in Japan on June 4, who then filled out the proxy card(s) and delivered them to the issuer" (date unspecified).

## Appendix E

### Sample questionnaire (for investment managers)

***Anonymised Investment Manager Questionnaire***

The identities of the global custodians and voting agents used in the original questionnaire have been replaced with code identifiers

**International Corporate Governance Network**

**Cross Border Voting Study 2002**

**Conducted by Institutional Design Ltd**

Thank you for agreeing to participate in this study. A representative from Institutional Design will be contacting you shortly to arrange a telephone interview. In advance of the interview, we would be grateful if you could complete the following self-completion questionnaire. Although some elements of the questionnaire may not be applicable to you, please ensure that you answer all questions to the best of your ability. All information will be held in confidence by the Institutional Design research team.

Please complete the questionnaire in **electronic** (rather than hard copy) format and return the completed questionnaires, by email, to [DL@institutionaldesign.com](mailto:DL@institutionaldesign.com)

Your Name	
Title	
Firm	
Address	
Telephone	
Fax	
Email	

## General

For the issuers named below, what was the date of the AGM?

Issuer	ISIN	Date of AGM
UKCO		
USCO		
ITCO		
DECO		
JACO		

In the year 2002, did you exercise proxy votes in respect of the issuers named below? If not, please explain why.

Issuer	Proxy votes exercised	Comments
UKCO		
USCO		
ITCO		
DECO		
JACO		

## The Receipt of Proxy Voting Materials (UKCO)

**On what date and in what format (e.g. hard copy, email attachment, link to website) did you receive UKCO's ANNUAL REPORT AND ACCOUNTS?**

Custodian/Voting Agent	Date	Format	English language version (yes or no)
Voting Agent 02			
Global Custodian 01			
Global Custodian 03			
Global Custodian 05			

Note:

Annual report and accounts = report on financial performance of issuer

**Do you think UKCO should release the annual report and accounts any earlier? If so, please explain.**

**On what date and in what format (e.g. hard copy, telex, fax, swift, proprietary electronic link, email text, email attachment or link to website) did you receive UKCO's NOTICE OF MEETING? Please also indicate whether you received the full text of the notice of meeting or whether this was abridged in any way.**

Custodian/Voting Agent	Date	Format	English language version (yes or no)	Abridged? If so, in what way?
Voting Agent 02				
Global Custodian 01				
Global Custodian 03				
Global Custodian 05				

Notes:

Notice of meeting = agenda of business to be transacted at the meeting

Proxy cards = form on which voting instructions are given

**Please specify all other means by which you received UKCO's proxy materials (e.g. newspapers or via other 3<sup>rd</sup> parties e.g. proxy solicitors).**

**Do you think UKCO should publish the notice of meeting any earlier? If so, please explain.**

**Did you send CONFIRMATION (to your custodians/voting agents) that you had received the UKCO proxy materials sent to you? If you did provide confirmation, please indicate the date and format of the confirmation (e.g. email, fax etc.)**

Custodian/Voting Agent	Date	Format
Voting Agent 02		
Global Custodian 01		
Global Custodian 03		
Global Custodian 05		

## The Receipt of Proxy Voting Materials (USCO)

On what date and in what format (e.g. hard copy, email attachment, link to website) did you receive USCO's ANNUAL REPORT AND ACCOUNTS?

Custodian/Voting Agent	Date	Format	English language version (yes or no)
Voting Agent 01			
Global Custodian 01			
Global Custodian 02			
Global Custodian 03			
Global Custodian 04			
Global Custodian 05			
Global Custodian 06			
Global Custodian 07			
Global Custodian 08			

Do you think USCO should release the annual report and accounts any earlier? If so, please explain.

On what date and in what format (e.g. hard copy, telex, fax, swift, proprietary electronic link, email text, email attachment or link to website) did you receive USCO's NOTICE OF MEETING? Please also indicate whether you received the full text of the notice of meeting or whether this was abridged in any way.

Custodian/Voting Agent	Date	Format	English language version (yes or no)	Abridged? If so, in what way?
Voting Agent 01				
Global Custodian 01				
Global Custodian 02				
Global Custodian 03				
Global Custodian 04				
Global Custodian 05				
Global Custodian 06				
Global Custodian 07				
Global Custodian 08				

Please specify all other means by which you received USCO's proxy materials (e.g. newspapers or via other 3<sup>rd</sup> parties e.g. proxy solicitors).

**Do you think USCO should publish the notice of meeting any earlier? If so, please explain?**

--

**Did you send CONFIRMATION (to your custodians/voting agents) that you had received the USCO proxy materials sent to you? If you did provide confirmation, please indicate the date and format of the confirmation (e.g. email, fax etc.)**

Custodian/Voting Agent	Date	Format
Voting Agent 01		
Global Custodian 01		
Global Custodian 02		
Global Custodian 03		
Global Custodian 04		
Global Custodian 05		
Global Custodian 06		
Global Custodian 07		
Global Custodian 08		

## The Receipt of Proxy Voting Materials (ITCO)

On what date and in what format (e.g. hard copy, email attachment, link to website) did you receive ITCO's ANNUAL REPORT AND ACCOUNTS?

Custodian/Voting Agent	Date	Format	English language version (yes or no)
Voting Agent 02			
Global Custodian 03			
Global Custodian 05			

Do you think ITCO should release the annual report and accounts any earlier? If so, please explain.

On what date and in what format (e.g. hard copy, telex, fax, swift, proprietary electronic link, email text, email attachment or link to website) did you receive ITCO's NOTICE OF MEETING? Please also indicate whether you received the full text of the notice of meeting or whether this was abridged in any way.

Custodian/Voting Agent	Date	Format	English language version (yes or no)	Abridged? If so, in what way?
Voting Agent 02				
Global Custodian 03				
Global Custodian 05				

Please specify all other means by which you received ITCO's proxy materials (e.g. newspapers or via other 3<sup>rd</sup> parties e.g. proxy solicitors).

Do you think ITCO should publish the notice of meeting any earlier? If so, please explain?

Did you send CONFIRMATION (to your custodians/voting agents) that you had received the ITCO proxy materials sent to you? If you did provide confirmation, please indicate the date and format of the confirmation (e.g. email, fax etc.)

Custodian/Voting Agent	Date	Format
Voting Agent 02		
Global Custodian 03		
Global Custodian 05		

## The Receipt of Proxy Voting Materials (DECO)

On what date and in what format (e.g. hard copy, email attachment, link to website) did you receive DECO's ANNUAL REPORT AND ACCOUNTS?

Custodian/Voting Agent	Date	Format	English language version (yes or no)
Voting Agent 02			
Global Custodian 05			
Global Custodian 03			
Global Custodian 01			

Do you think DECO should release the annual report and accounts any earlier? If so, please explain.

On what date and in what format (e.g. hard copy, telex, fax, swift, proprietary electronic link, email text, email attachment or link to website) did you receive DECO's NOTICE OF MEETING? Please also indicate whether you received the full text of the notice of meeting or whether this was abridged in any way.

Custodian/Voting Agent	Date	Format	English language version (yes or no)	Abridged? If so, in what way?
Voting Agent 02				
Global Custodian 05				
Global Custodian 03				
Global Custodian 01				

Please specify all other means by which you received DECO's proxy materials (e.g. newspapers or via other 3<sup>rd</sup> parties e.g. proxy solicitors).

Do you think DECO should publish the notice of meeting any earlier? If so, please explain?

Did you send CONFIRMATION (to your custodians/voting agents) that you had received the DECO proxy materials sent to you? If you did provide confirmation, please indicate the date and format of the confirmation (e.g. email, fax etc.)

Custodian/Voting Agent	Date	Format
Voting Agent 02		
Global Custodian 05		
Global Custodian 03		
Global Custodian 01		

## The Receipt of Proxy Voting Materials (JACO)

**On what date and in what format (e.g. hard copy, email attachment, link to website) did you receive JACO's ANNUAL REPORT AND ACCOUNTS?**

Custodian/Voting Agent	Date	Format	English language version (yes or no)
Voting Agent 02			
Global Custodian 05			
Global Custodian 03			
Global Custodian 01			
Global Custodian 02			

**Do you think JACO should release the annual report and accounts any earlier? If so, please explain.**

**On what date and in what format (e.g. hard copy, telex, fax, swift, proprietary electronic link, email text, email attachment or link to website) did you receive JACO's NOTICE OF MEETING? Please also indicate whether you received the full text of the notice of meeting or whether this was abridged in any way.**

Custodian/Voting Agent	Date	Format	English language version (yes or no)	Abridged? If so, in what way?
Voting Agent 02				
Global Custodian 05				
Global Custodian 03				
Global Custodian 01				
Global Custodian 02				

**Please specify all other means by which you received JACO's proxy materials (e.g. newspapers or via other 3<sup>rd</sup> parties e.g. proxy solicitors).**

**Do you think JACO should publish the notice of meeting any earlier? If so, please explain?**

**Did you send CONFIRMATION (to your custodians/voting agents) that you had received the JACO proxy materials sent to you? If you did provide confirmation, please indicate the date and format of the confirmation (e.g. email, fax etc.)**

Custodian/Voting Agent	Date	Format
Voting Agent 02		
Global Custodian 05		
Global Custodian 03		
Global Custodian 01		
Global Custodian 02		

## The Return of Proxy Voting Instructions

On what date and in what format (e.g. standing instruction, hard copy proxy, telex, fax proxy, swift, proprietary electronic link, email text, email attachment) did you provide voting instructions to your custodians/voting agents?

Voting Instructions (UKCO)		
Custodian/Voting Agent	Date sent	Format provided
Voting Agent 02		
Global Custodian 01		
Global Custodian 03		
Global Custodian 05		

Voting Instructions (USCO)		
Custodian/Voting Agent	Date sent	Format provided
Voting Agent 01		
Global Custodian 01		
Global Custodian 02		
Global Custodian 03		
Global Custodian 04		
Global Custodian 05		
Global Custodian 06		
Global Custodian 07		
Global Custodian 08		

Voting Instructions (ITCO)		
Custodian/Voting Agent	Date sent	Format provided
Voting Agent 02		
Global Custodian 03		
Global Custodian 05		

Voting Instructions (DECO)		
Custodian/Voting Agent	Date sent	Format provided
Voting Agent 02		
Global Custodian 05		
Global Custodian 03		
Global Custodian 01		

<b>Voting Instructions (JACO)</b>		
Custodian/Voting Agent	Date sent	Format provided
Voting Agent 02		
Global Custodian 05		
Global Custodian 03		
Global Custodian 01		
Global Custodian 02		

**Did you obtain confirmation from your custodians/voting agents that they had received and acted upon your voting instructions? If so, please indicate the date and format of the confirmation (e.g. email, fax etc.)**

<b>Confirmation of Voting Instructions (UKCO)</b>		
Custodian/Voting Agent	Date of confirmation	Format provided
Voting Agent 02		
Global Custodian 01		
Global Custodian 03		
Global Custodian 05		

<b>Confirmation of Voting Instructions (USCO)</b>		
Custodian/Voting Agent	Date of confirmation	Format provided
Voting Agent 01		
Global Custodian 01		
Global Custodian 02		
Global Custodian 03		
Global Custodian 04		
Global Custodian 05		
Global Custodian 06		
Global Custodian 07		
Global Custodian 08		

<b>Confirmation of Voting Instructions (ITCO)</b>		
Custodian/Voting Agent	Date of confirmation	Format provided
Voting Agent 02		
Global Custodian 03		
Global Custodian 05		

<b>Confirmation of Voting Instructions (DECO)</b>		
Custodian/Voting Agent	Date of confirmation	Format provided
Voting Agent 02		
Global Custodian 05		
Global Custodian 03		
Global Custodian 01		

<b>Confirmation of Voting Instructions (JACO)</b>		
<b>Custodian/Voting Agent</b>	<b>Date of confirmation</b>	<b>Format provided</b>
Voting Agent 02		
Global Custodian 05		
Global Custodian 03		
Global Custodian 01		
Global Custodian 02		

## Further Comments

Over the past three years, have you asked your custodians/voting agents to report on your execution of proxy votes? Please answer with respect to the following institutions:

Voting Agent 01	
Voting Agent 02	
Global Custodian 01	
Global Custodian 02	
Global Custodian 03	
Global Custodian 04	
Global Custodian 05	
Global Custodian 06	
Global Custodian 07	
Global Custodian 08	

Over the next two years, are you planning to change any of the procedures/formats by which you receive proxy voting materials and provide proxy voting instructions?

--

What do you see as the greatest obstacles to cross border voting in each of the following countries?

UK	
USA	
Italy	
Germany	
Japan	